

Recent Developments on Superconducting Acceleration Technology relevant for EURISOL

Sébastien Bousson



CNRS/IN2P3/ IPN– Paris-Sud University

Eurisol Topical and Town Meetings, Lisbon, 15th–19th October 2012



Outlook

- R&D on spoke cavities for Eurisol
- TIARA (WP 9)
- SARAF
- Spiral-2
- IFMIF
- SRF Developments for ESS
- HIE Isolde
- EUCARD – SPL activities
- MYRRHA
- Conclusion

EURISOL Accelerator Layout

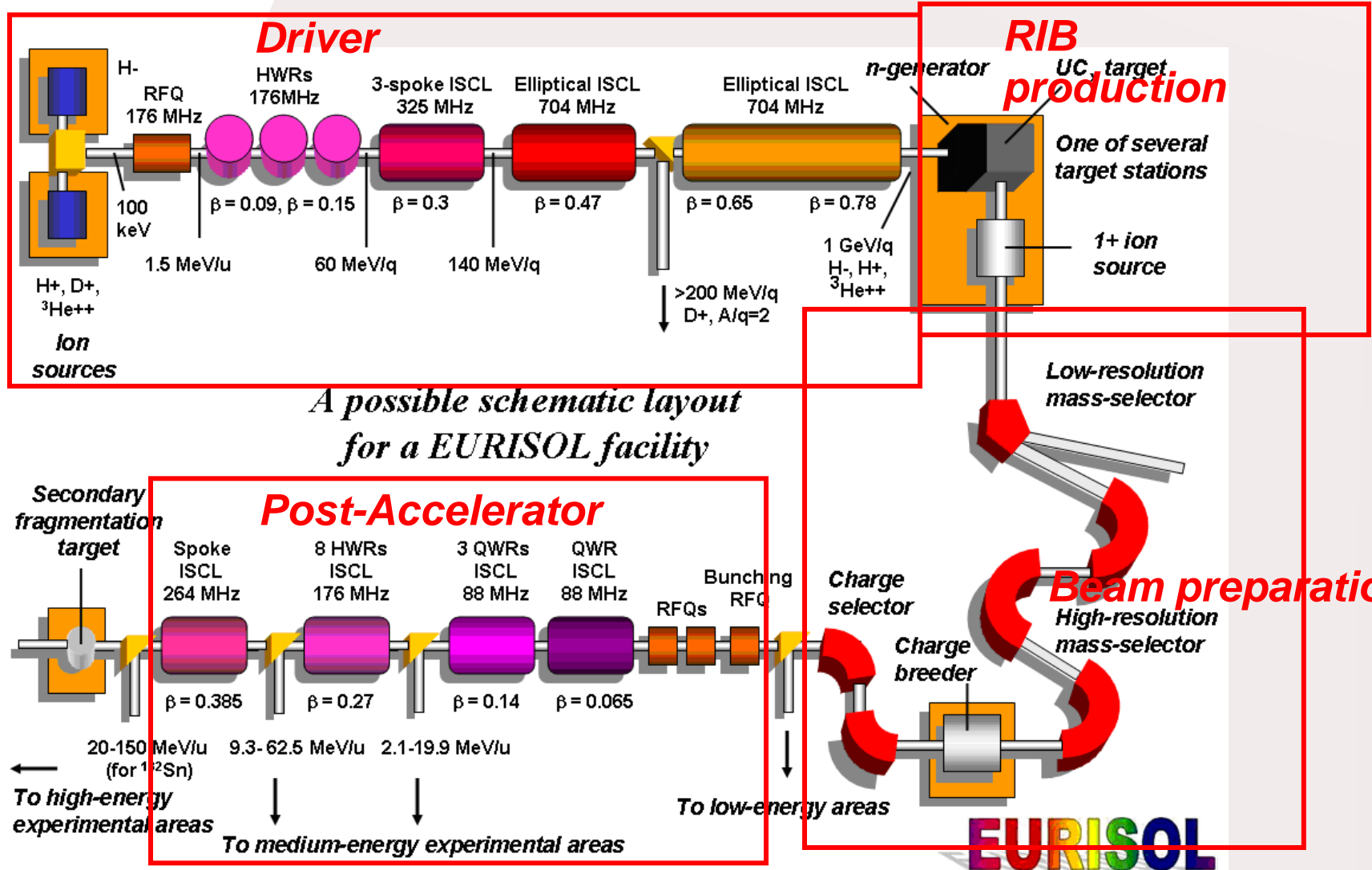

Why High Power Accelerators ?

Secondary beams produced by a high energy proton beam in a target : 5 applications in fundamental and applied research

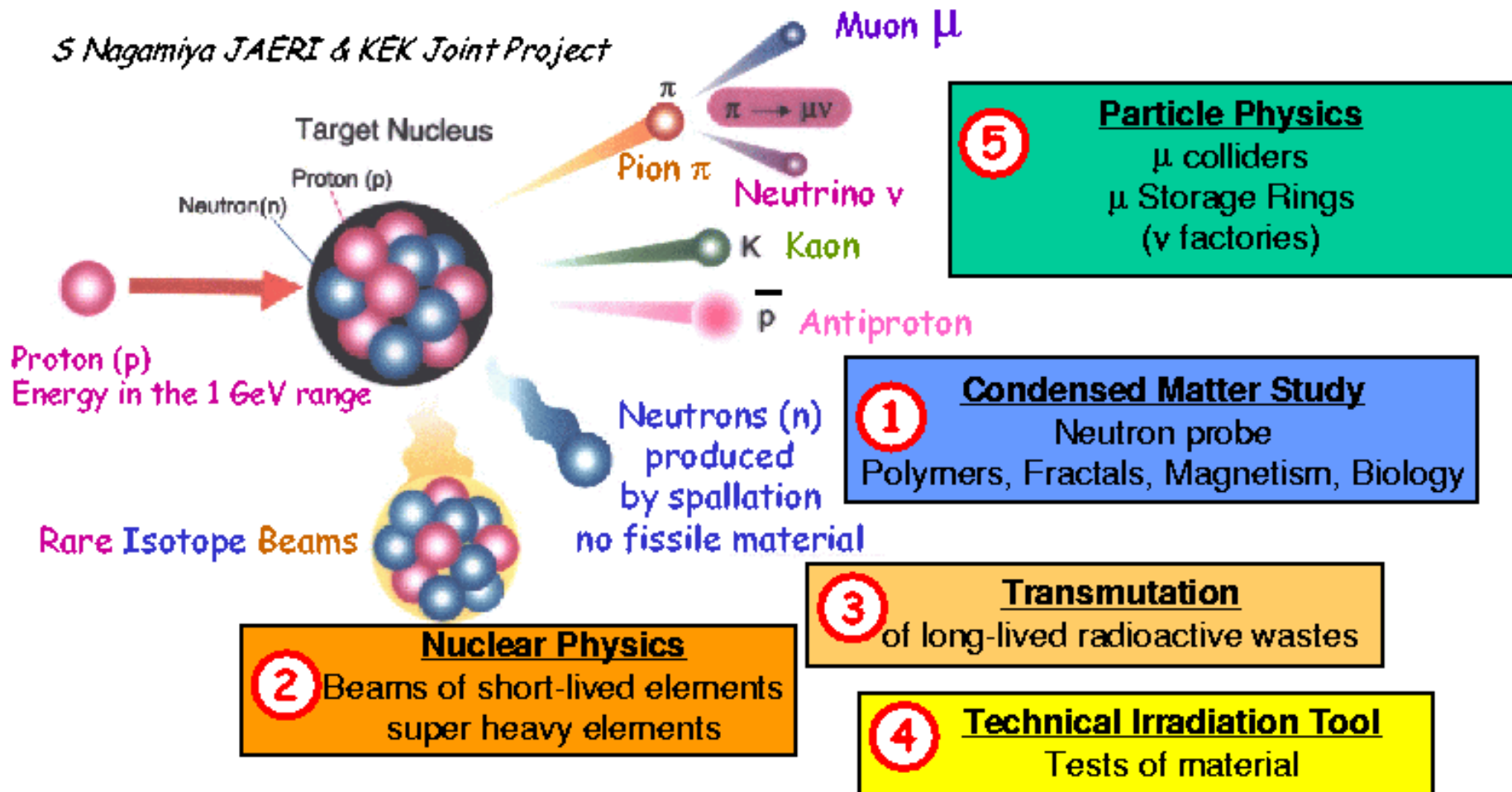

EURISOL related activities (IPN Orsay)

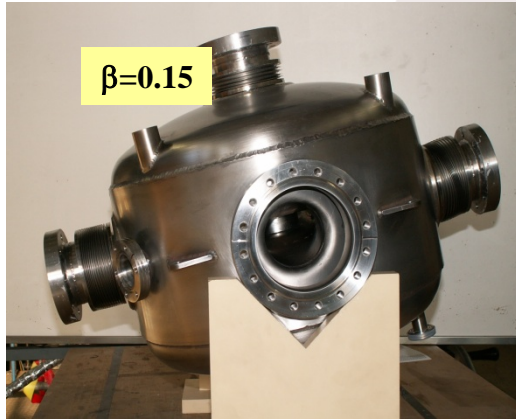

Spoke resonators

Two prototypes @ 352 MHz
(β 0.15 and β 0.35)
fabricated and tested.



Horizontal cryostat

Adapted to spoke cavities for 4K and 2K tests

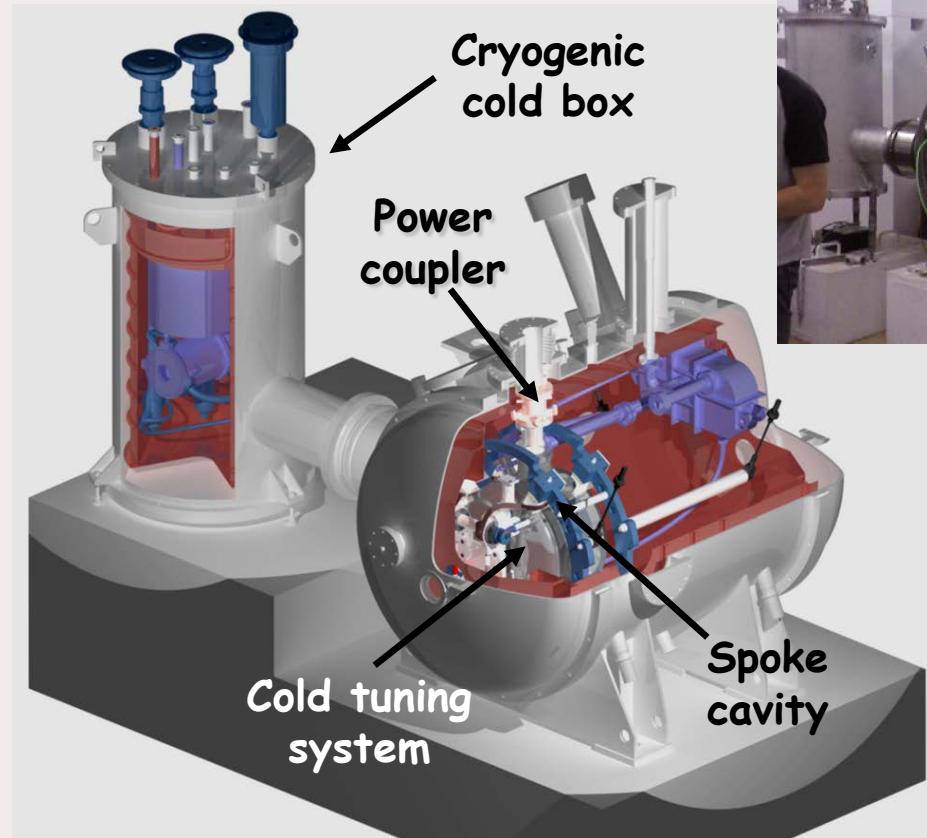

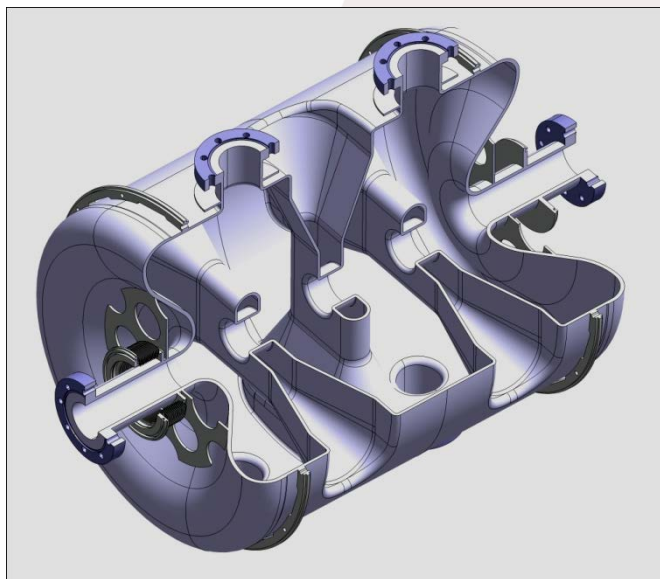

A triple spoke cavity has been designed during the Eurisol DS. The cavity fabrication has been launched and achieved in sept. 2011

After a first surface preparation (chemical etching and high pressure rinsing), a first cryogenic test was performed in the beginning of 2012.

**First result in vertical cryostat:
Maximum achieved Eacc was 3.5 MV/m, limited by a quench -> a new surface treatment will be done and a quench location detection system will be implemented (based on second sound wave) to localize the quench site.**



In the meantime, adaptation of the CMO horizontal cryostat is in progress to integrate the fully equipped triple spoke.

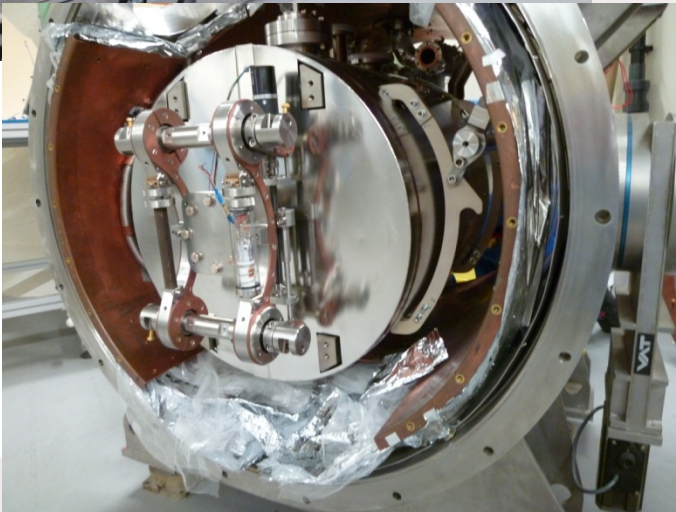

This experiment will allow to test a new type of tuning system: a niobium plunger inside the cavity volume (as developed by IPNO for Spiral-2), for the first time implemented on a spoke cavity.

TIARA (EU)



Creation of a coordinated panEuropean multi-purpose distributed Test Infrastructure

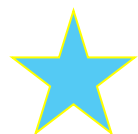

Monitoring and coordinating the use and the development of the European test infrastructures for accelerator R&D

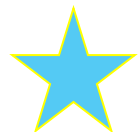

Monitoring accesses, including industry involvement

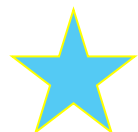

Identifying weaknesses and needed upgrades/investments and assessing their costs



Making recommendations and contributing to upgrade and/or construction of new R&D Infrastructures as well as their corresponding R&D programs

The objective of this WP is to coordinate the definition and the engineering design of two test benches of highest interest for Eurisol:

- an irradiation test facility for the high power target developments
- a test cryostat for testing fully equipped low beta superconducting cavities.



- **Specifications**

- Adapted for various geometries; QWR, HWR, Spoke (single gap, multigap)...
- Various configuration of power couplers and cold tuning systems
- Could integrate a SC solenoid to test impact off fringe fields on the cavity performances
- Operation at 4K and 2K

Starting from the user requirements and specifications of the test cryostat was achieved, the conceptual design study is under progress.

The main difficulty is the required versatility for the cryostat to fit a wide range of cavity geometries populating the low beta cavity “bestiary”:

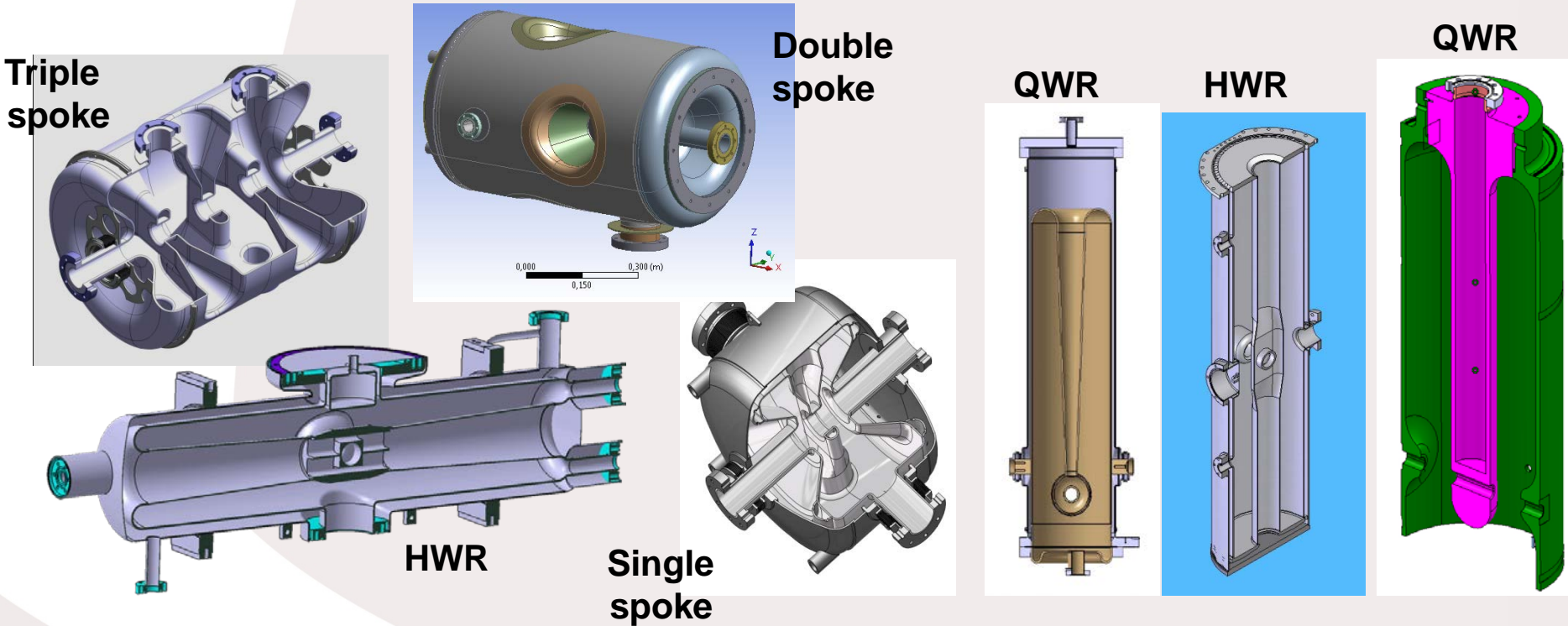

As expressed by the users, the cryostat should also allow the possibility to insert a superconducting magnet close to the cavity.

Several cryostat configurations have been investigated to define the most appropriate solution for the required versatility:

1/ Cylindrical configuration: the cavity alone, or the string formed by the equipped cavity + magnet assembled in the clean room is horizontally inserted in the cryostat.

Illustrated here with a triple spoke cavity: rather simple configuration, but not adapted (or not optimized) for cavities which have a “vertical” geometry (HWR, QWR)

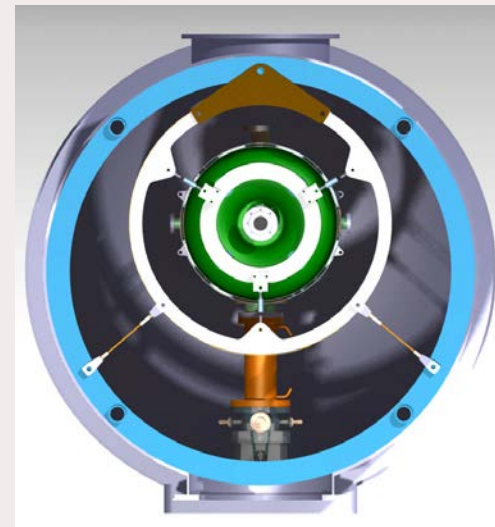

2/ Top-loaded configuration with a “vertical cryostat like” assembly (ANL)

Difficulties with this solution are the clean room assembly tooling which should be specific for each cavity and the large height required in the assembly hall to “load” the large cryostat bottom part.

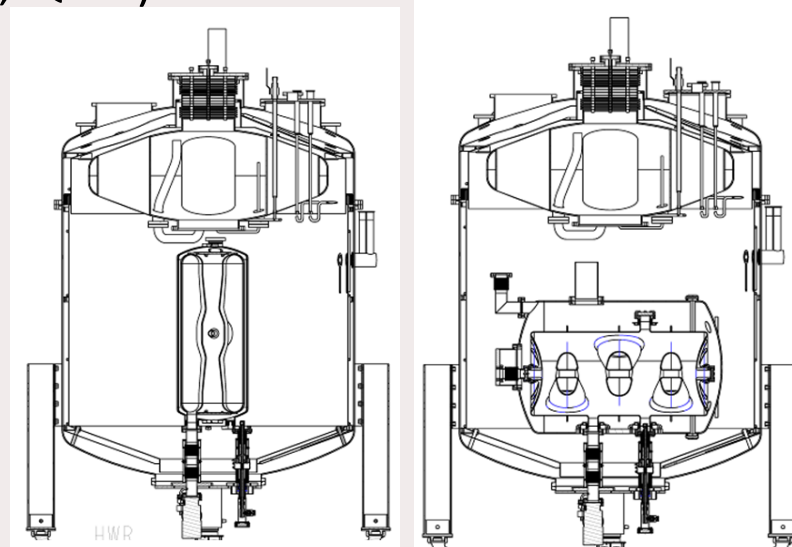

3/ Another top loaded configuration, but with a cryostat separated in 3 parts, the intermediate parts being the support tooling for the clean room assembly (inspired from SP2 cryomodule design).

Most versatile solution, well adapted to several cavity / coupler configurations

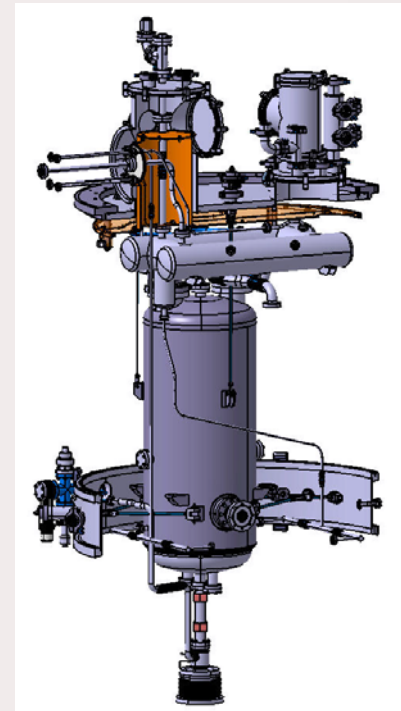
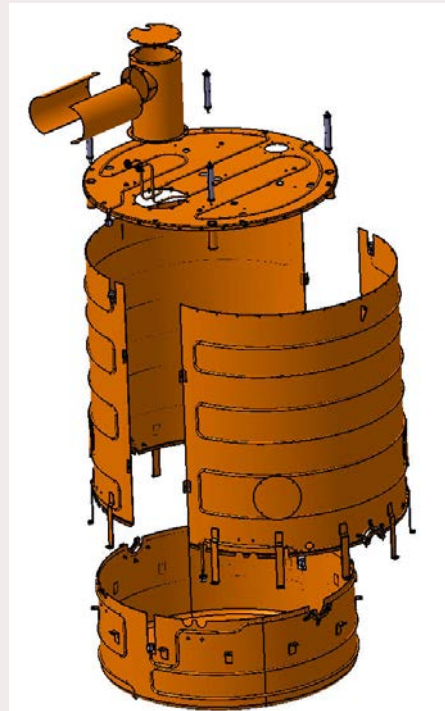
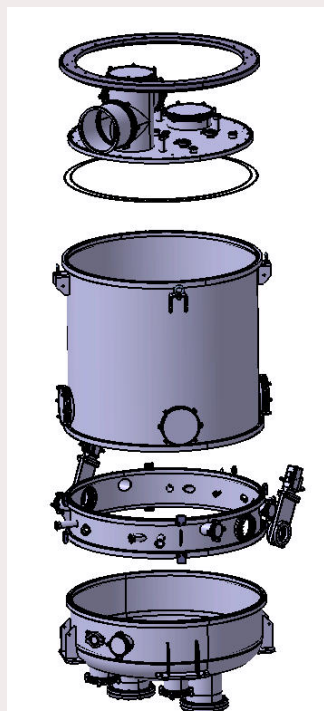

The cryostat diameter will be about 1.9 m to accommodate the longest cavity, typically triple spokes, and “rather high” beta (about 0.5). Difficulties exits to cope with one “exotic” configuration which is the horizontal assembly of half-wave cavities (IFMIF case) -> larger cryostat might be required (under study).

SARAF (Soreq, Israel)

EURISOL Accelerator Layout

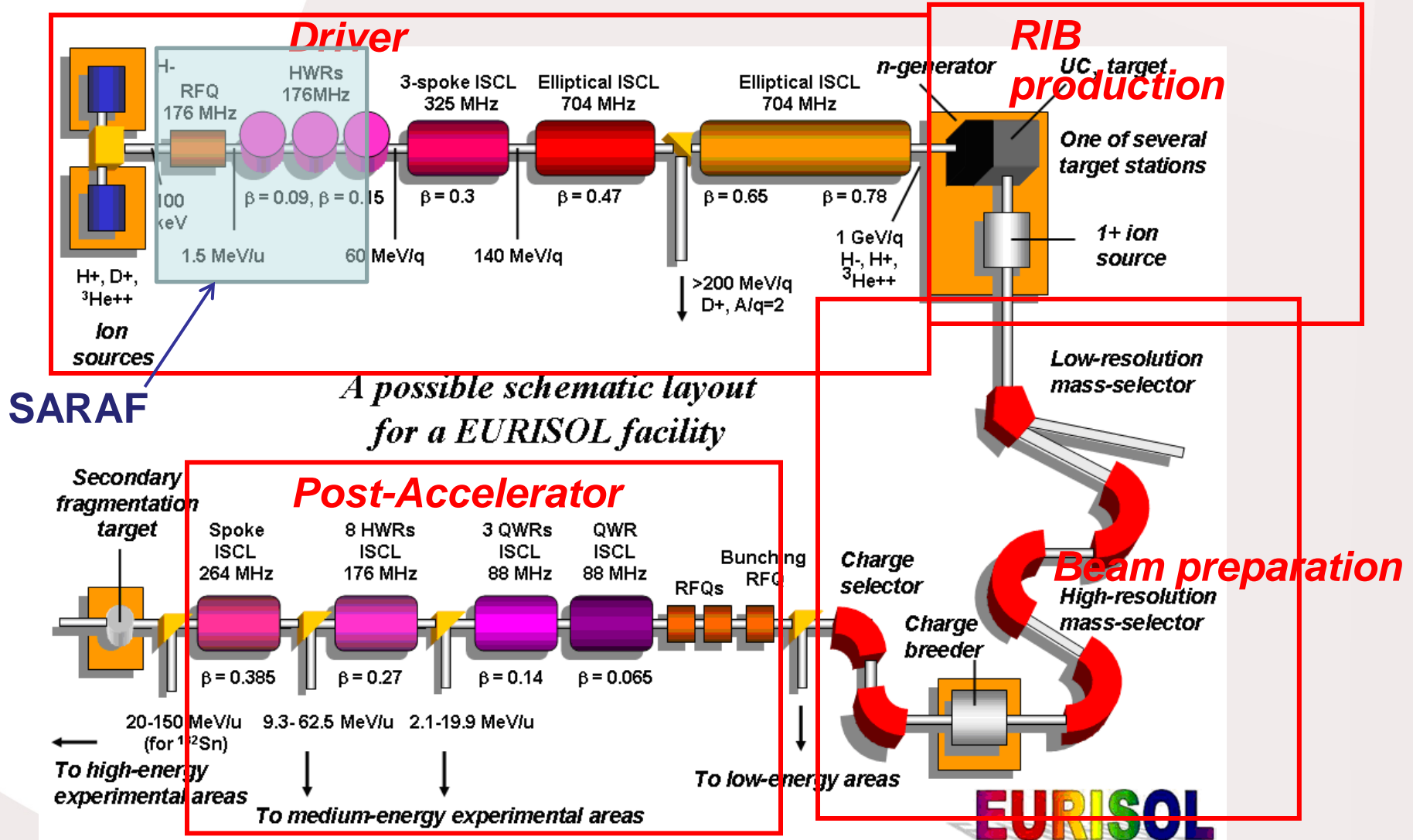

Project objectives: SARAF phase 1 : a 2 mA protons and deuterons beam up to 4 MeV (resp. 5 MeV).

Cavity type: 6 Half-wave resonators / module; beta 0.09 @ 176 MHz.

Specifications: $P < 10$ W/cavity @ $E_{pk} = 25$ MV/m ($E_{acc} = 5$ MV/m)

PSM Cryomodule test:

- Each of the cavities individually reached stable operation at its specified field (E_{pk} of 25 MV/m, corresponding to a voltage of 840 kV).
- FE: Improvement after He processing (a few 10^{-5} mbar)
- Difficulties with stable simultaneous operation of all cavities at nominal field due to cavity high sensitivity to He pressure variations (60 Hz/mbar).
-> difficult to compensate with the tuner (strong hysteresis)
- Increase of available RF power from 2 to 4 kW to compensate

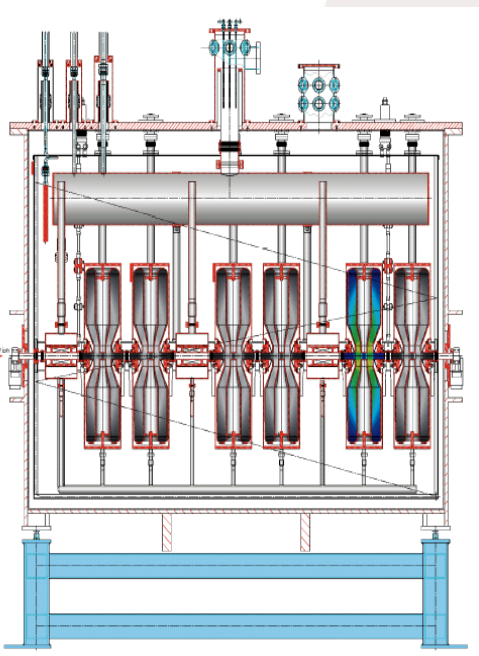

Courtesy I. Mardor

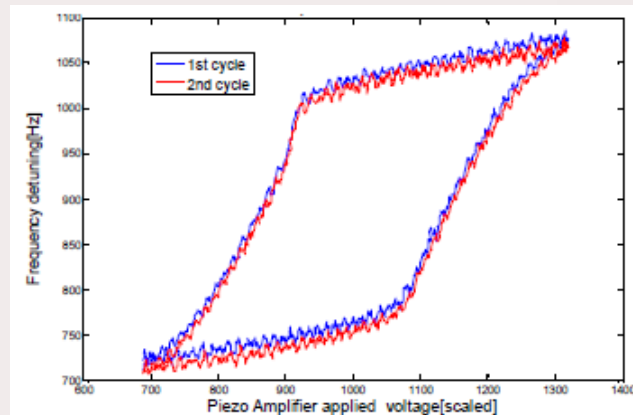

SPIRAL-2

(GANIL, France)

Project objectives: construction of a 40 MeV deuterons accelerator (which can also accelerate $q/A = 1/3$ and $1/6$) as a driver for RIB production

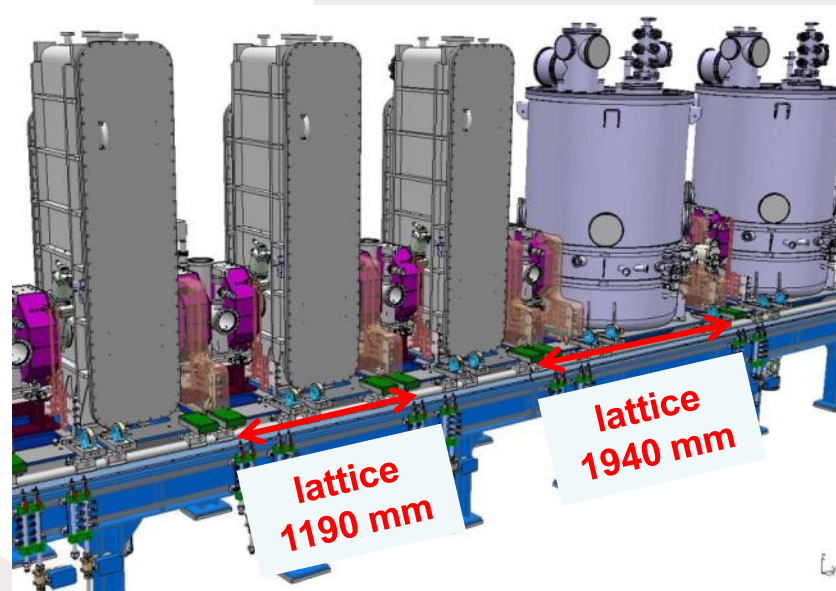
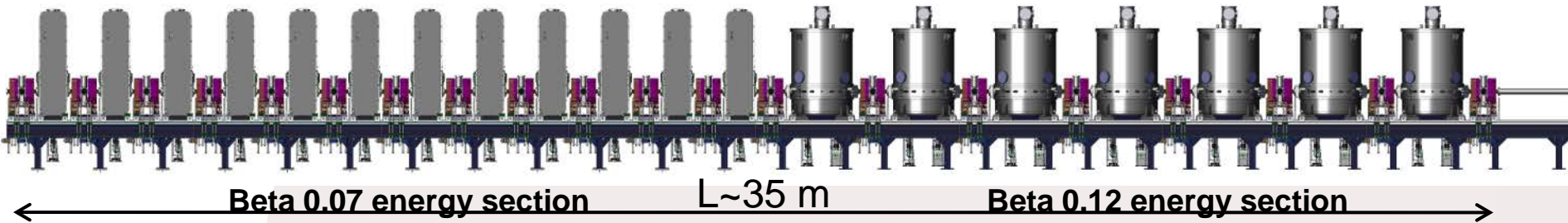

| | | |
|---------------------|---------------------|----------------------|
| Cryomodule A | Cryomodule B | Power coupler |
| CEA Saclay | IPN Orsay | LPSC Grenoble |

| Cryomodule | A | B |
|--------------------------------------|-------|-------|
| Valve-to-valve length [mm] | 610 | 1360 |
| # cavities | 12 | 14 |
| f [MHz] | 88.05 | 88.05 |
| β_{opt} | 0.07 | 0.12 |
| E_{pk}/E_{acc} | 5.36 | 4.76 |
| B_{pk}/E_{acc} [mT/MV/m] | 8.70 | 9.35 |
| r/Q [Ω] | 599 | 515 |
| V_{acc} @ 6.5 MV/m & β_{opt} | 1.55 | 2.66 |
| Lacc [m] | 0.24 | 0.41 |
| Beam tube \varnothing [mm] | 38 | 44 |

Low beta cavities (“A” type): developed by CEA Saclay: QWR with dismountable copper bottom flange

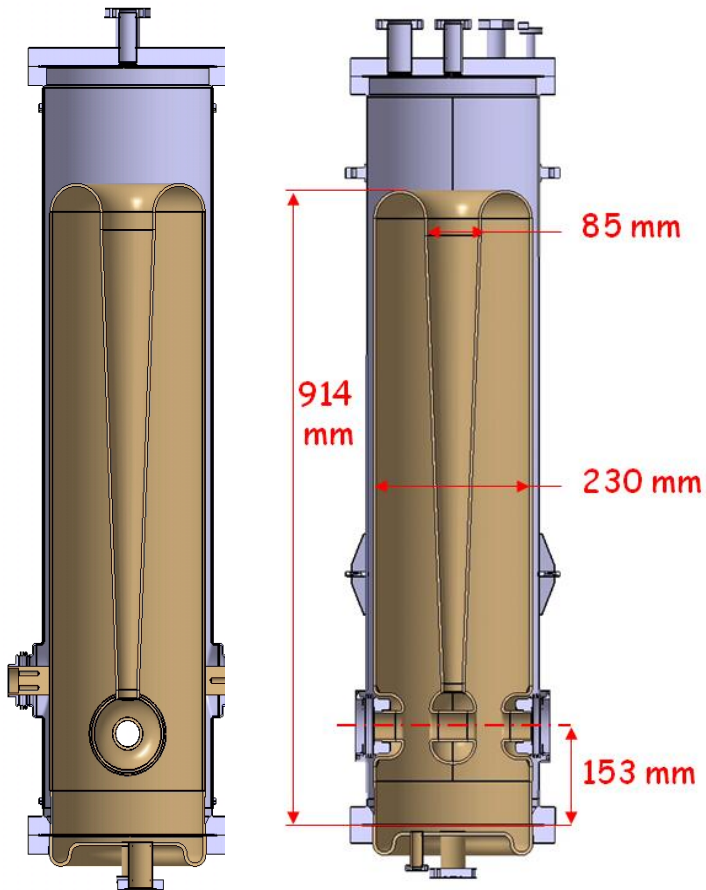

Courtesy P. Bosland

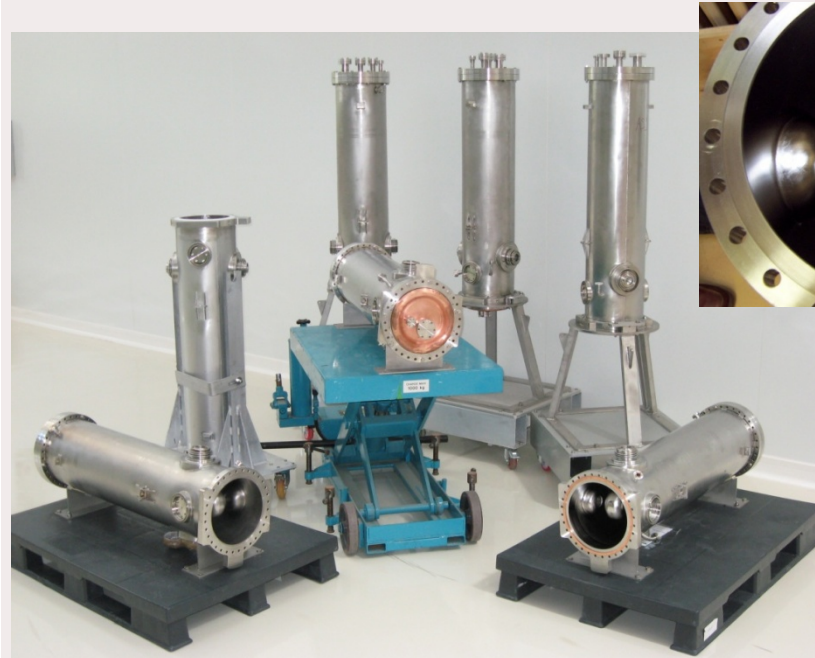

Zanon and SDMS cavities
All cavities fabricated and tested

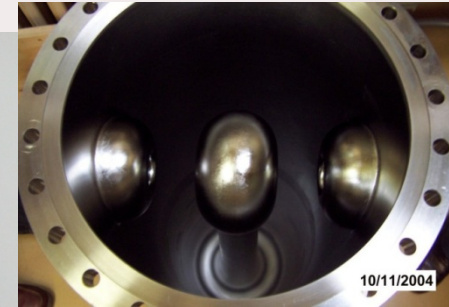

Performance Goal : 6.5 MV/m and 10 W max.

- Preparation: standard BCP, HPR @ 100 bar, class 10 clean room assembly
- All cavities exhibits multipacting. MP Barriers above 1 MV/m are easily processed. FE level and onset is variable, but when present, it is always processed in VT.
- Low β cavities: All 12 cavities tested are in the spec.
- High β cavities: all series cavity tested and in the spec with important margins !

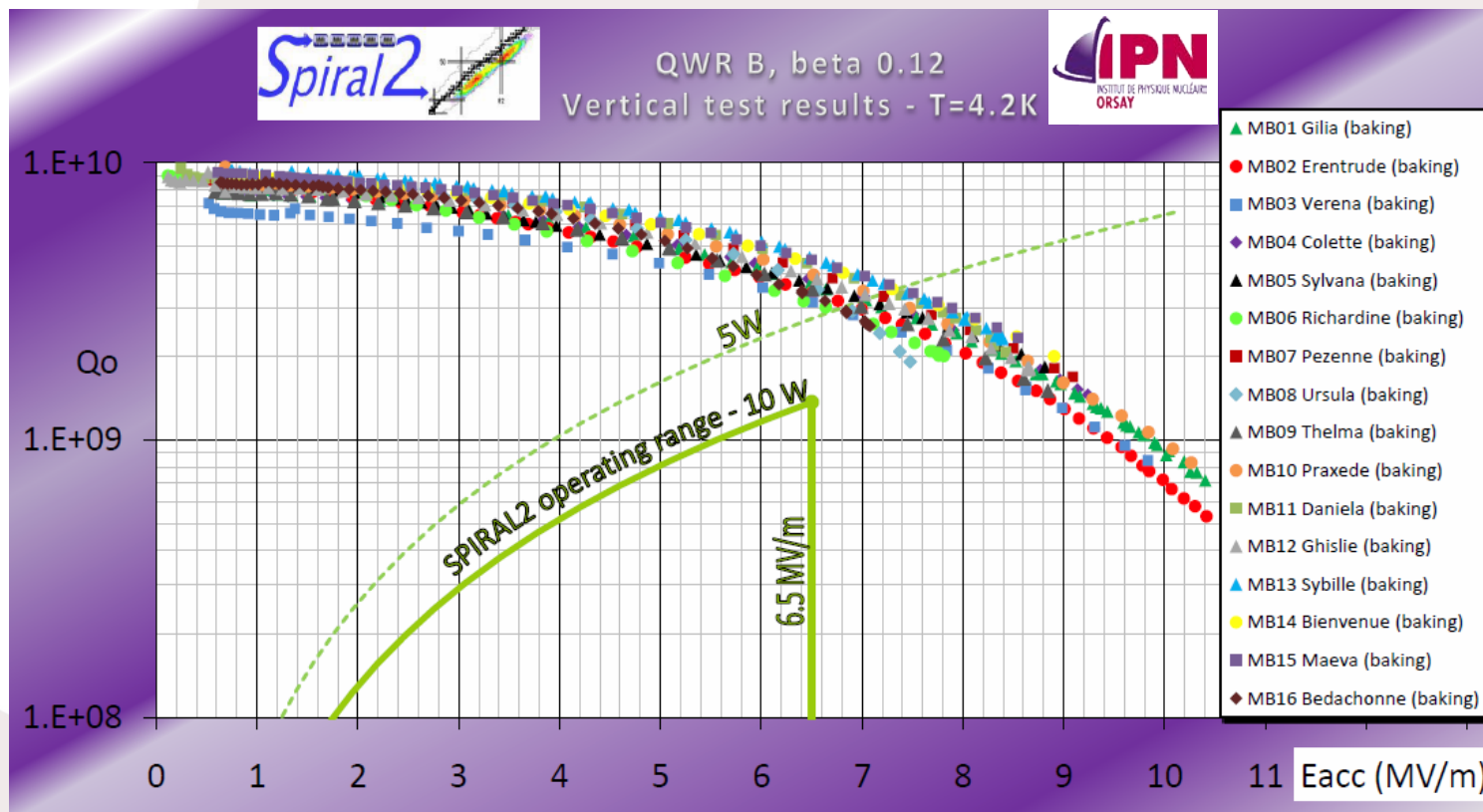

Performance Goal : 6.5 MV/m and 10 W max.

- Preparation: standard BCP, HPR @ 100 bar, class 10 clean room assembly
- All cavities exhibits multipacting. MP Barriers above 1 MV/m are easily processed. FE level and onset is variable, but when present, it is always processed in VT.
- Low β cavities: All 12 cavities tested are in the spec.
- High β cavities: all series cavity tested and in the spec with important margins !

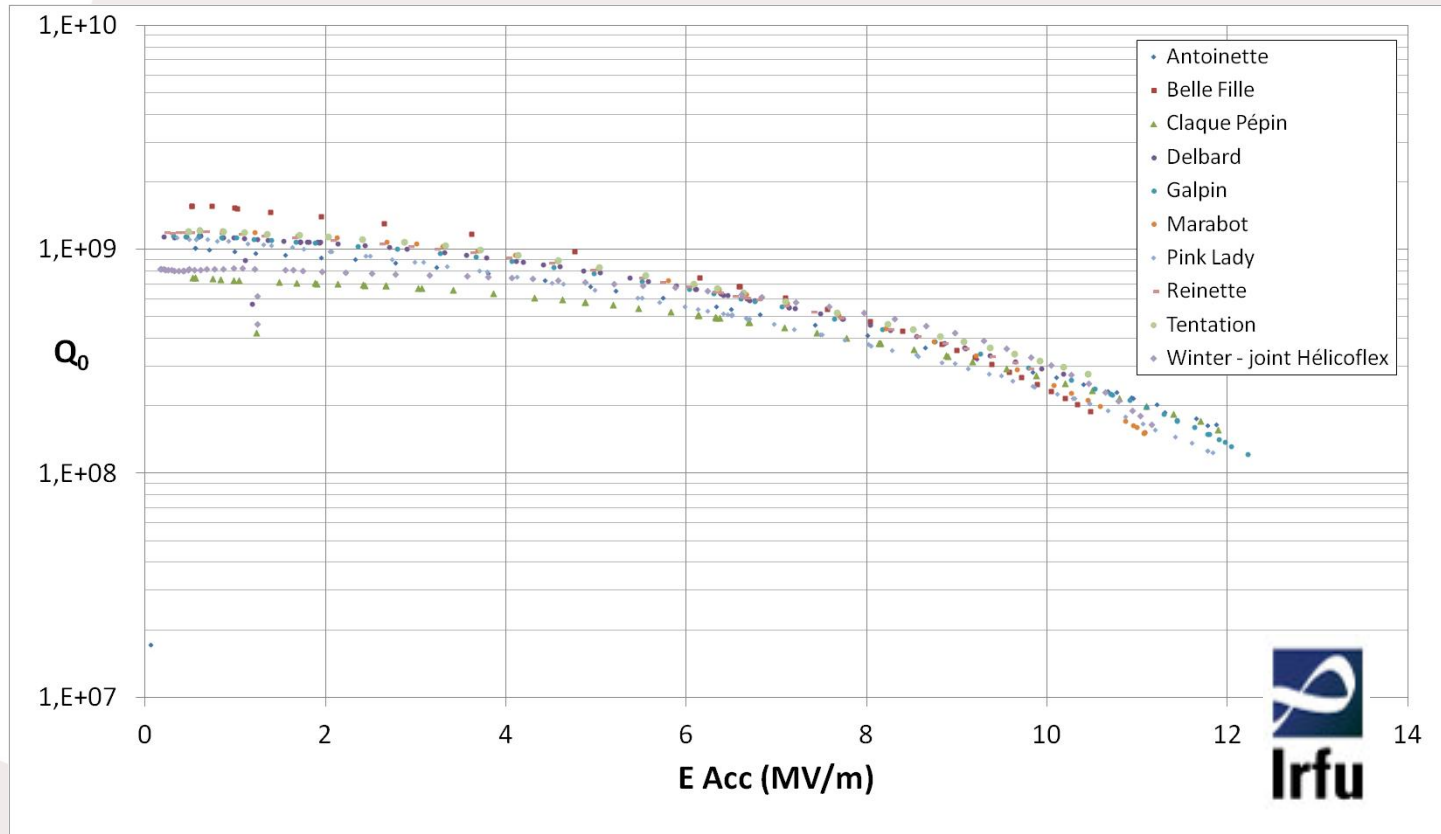

Courtesy G. Olry

High beta cavities : baking effect

- After 72h drying -> 48 h baking @ 120°C
- “Forced” air flow inside the helium vessel + heater on the cavity bottom
- Cavity wrapped in a foil blanket

| Cavity | Losses @ 6.5 MV/m [W] | |
|-------------------|-----------------------|-------------|
| | No baking | With baking |
| MB01 | 8.5 | 3.7 (-56%) |
| MB02 | 6.9 | 4.1 (-41%) |
| MB03 | 7.0 | 4.4 (-47%) |
| MB04 | 8.4 | 3.6 (-58%) |
| MB05 | 7.2 | 3.5 (-51%) |
| MB06 | 7.5 | 4.8 (-36%) |
| MB07 | 6.9 | 3.4 (-51%) |
| MB08 | X | 4.0 |
| MB09 | 8.9 | 3.9 (-56%) |
| MB10 | 7.1 | 3.5 (-51%) |
| MB11 | X | 3.1 |
| MB12 | X | 3.8 |
| MB13 | X | 3.0 |
| MB14 | X | 4.0 |
| MB15 | X | 3.1 |
| MB16 | X | 3.9 |
| Mean value | 7.6 | 3.7 |

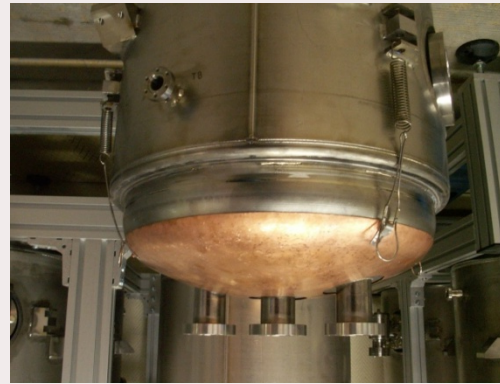

Heater (not shown) glued onto the copper cap

Output ~110°C

Losses divided by ~2 @ Eacc=6.5 MV/m

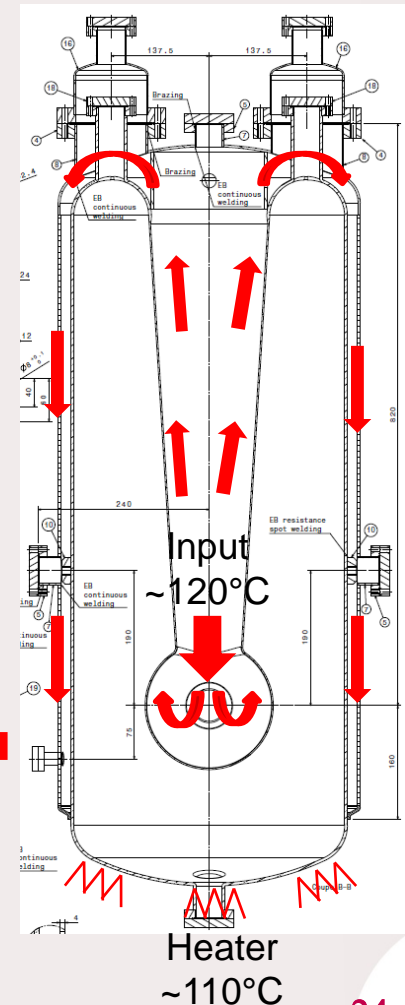

Low β Cold tuning system

Mechanical tuner, push system

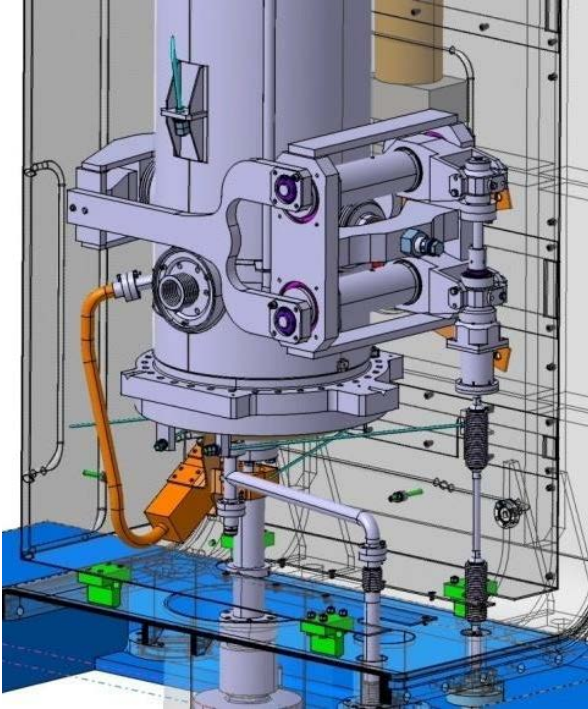

Good linearity: 0.15 Hz/motor step
Sensitivity: ~28 kHz/mm
Full range: +25 kHz

High β Cold tuning system

Tuning by insertion of an Nb rod

2 ports on the top of the cavity:

- One static plunger
- One moving plunger

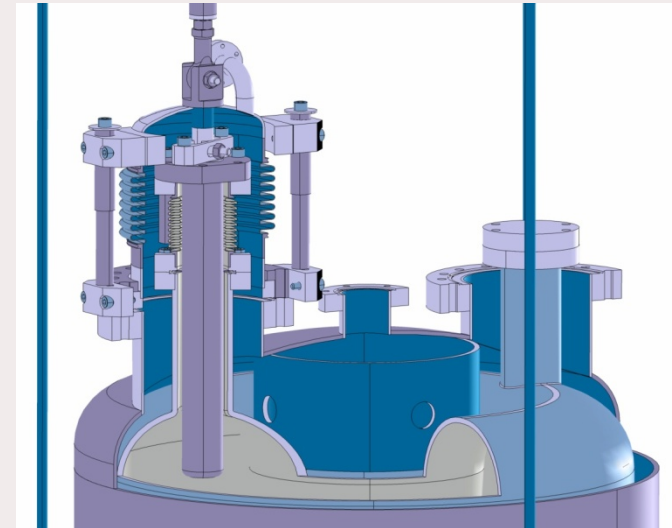

Sensitivity ~1 kHz/mm with \varnothing 30 mm plunger
Introducing one plunger by 50 mm (\varnothing 30 mm)

First “coarse” tuning: + 50 kHz
then fine tuning: +/- 4 kHz

Low β Cryomodule

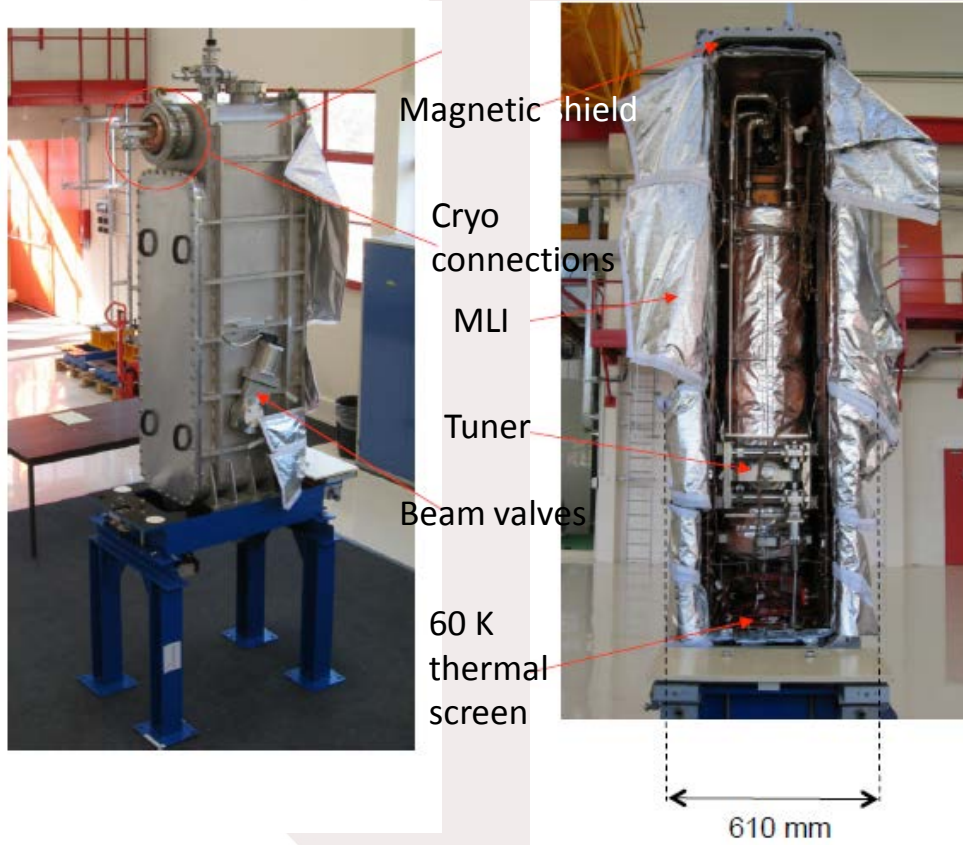

High β Cryomodule



Two different layout, but both have separated vacuum (clean string assembly)

Power couplers: developed, prepared and conditioned by LPSC Grenoble

Cryomodule results: the strong pollution-related difficulties coming from some parts (vacuum tubes, power couplers) are now solved. First cryomodule reached the nominal accelerating gradient 3 months ago.

IFMIF (EU, Japan)

Project objectives: characterization of materials with intense neutrons flux (10^{17} n/s) for the future Fusion Reactor DEMO (~ 150 dpa). Based on two CW 40 MeV deuterons SC linac, 125 mA each. **EU + Japan Collaboration**

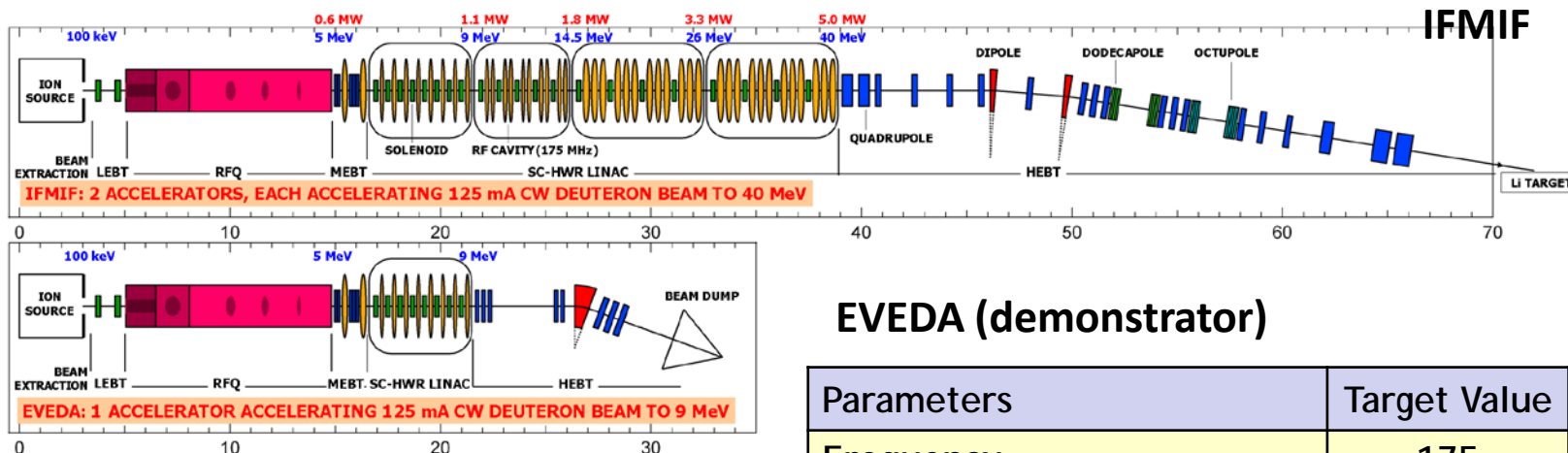

EVEDA (demonstrator)

| Parameters | Target Value | Units |
|---|-------------------|-------|
| Frequency | 175 | MHz |
| β value | 0.094 | |
| Accelerating field E_a | 4.5 | MV/m |
| Unloaded Quality factor Q_0 for $R_s=20$ n Ω | 1.4×10^9 | |
| Freq. range of HWR tuning syst | ± 50 | kHz |
| Max. transmitted RF power by coupler (CW) | 200 | kW |
| External quality factor Q_{ex} | 6.3×10^4 | |

Cavity type: Half-wave resonators

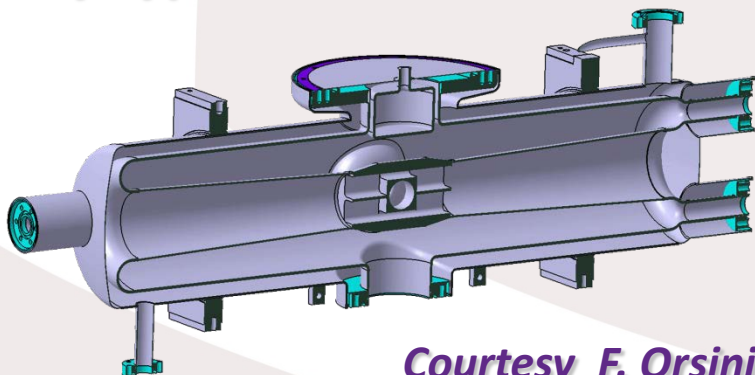

Courtesy F. Orsini

IFMIF Linac : 2 deuteron beams, 40 MeV, 125 mA CW each

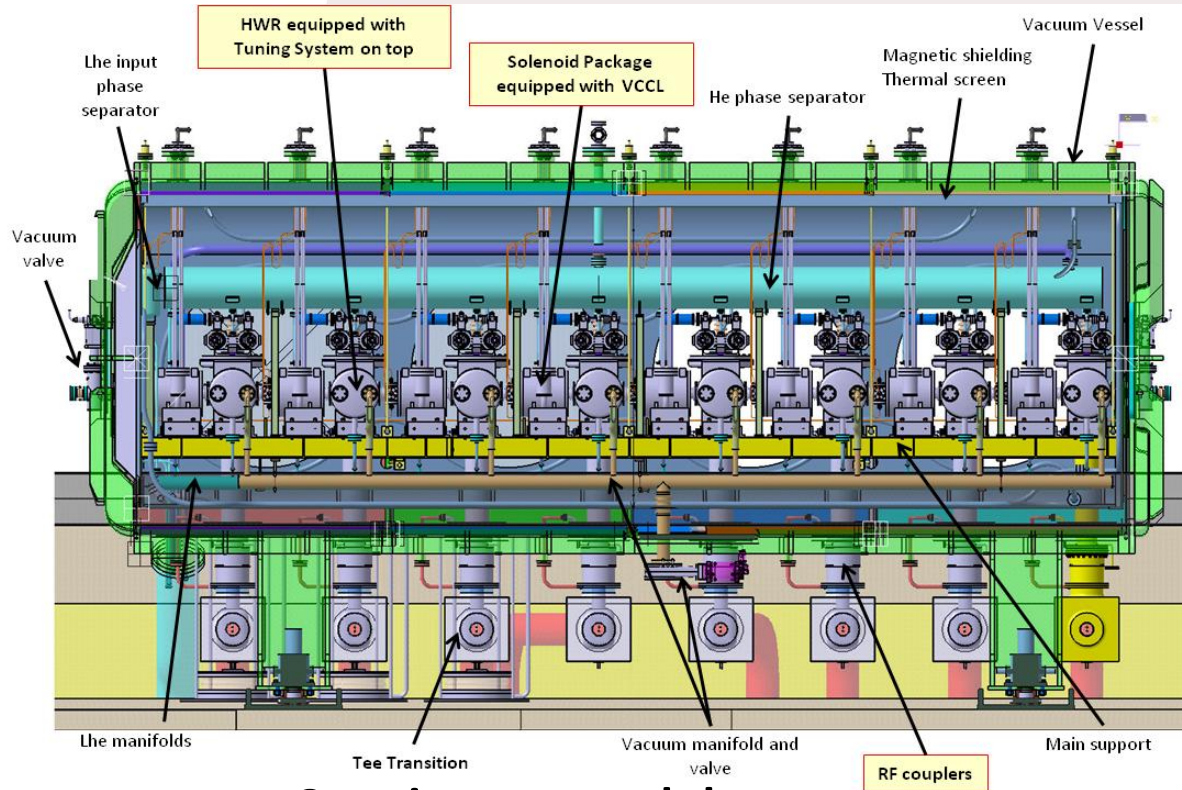
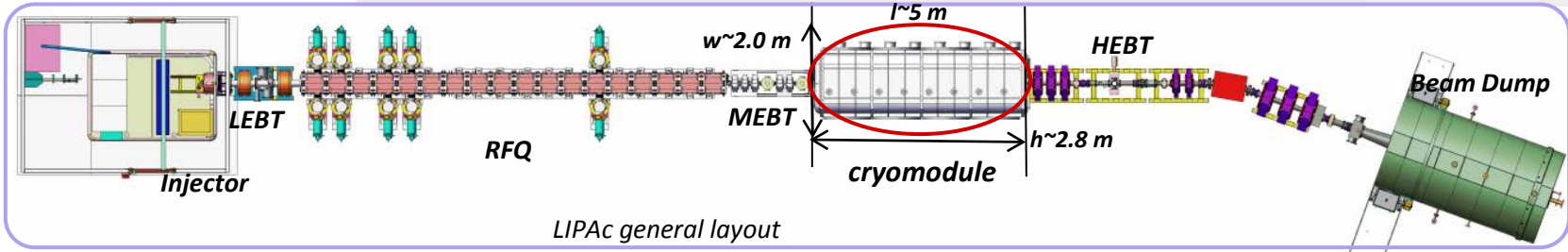

8 cavity cryomodule

S. Bousson – EURISOL Town Meeting – 17 to 18 Oct. 2012- Lisbon

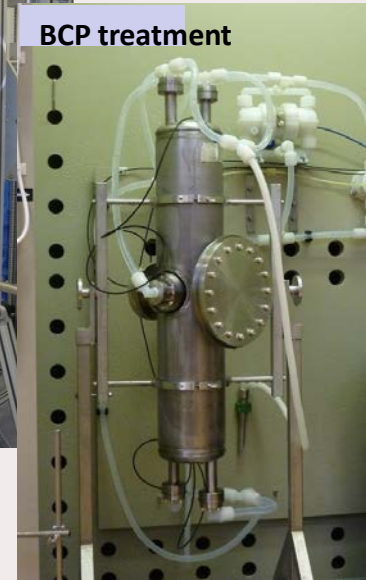

Surface treatment + clean room assembly @ IPNO

ESS
(Lund, Sweden)
SRF by IPNO and CEA

ESS Linac: High power proton accelerator, 5 MW

- Pulse 2.86 ms
- Rep. rate: 14 Hz
- Protons (H⁺)
- Low loss
- High reliability >95%
- Modular design for future upgrade



Investment cost: 1478 M€ over ~ 10 years

Operation cost: 106 M€ / year

Dismounting : 346 M€

(2008 costs)

ESS (European Spallation Source)

FDSL_2012_05_15

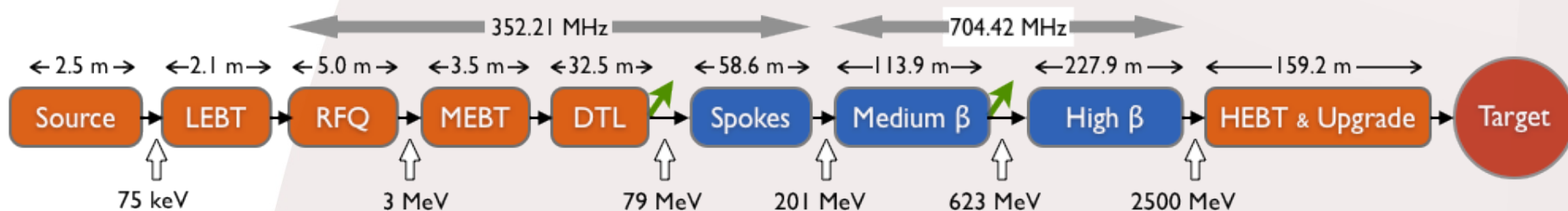

| | Length (m) | Input Energy (MeV) | Frequency (MHz) | Geometric β | # of Sections | Temp (K) |
|-------------------|------------|---------------------|-----------------|-------------------|--------------------|---------------|
| LEBT | 2.05 | 75×10^{-3} | -- | -- | -- | ≈ 300 |
| RFQ | 4.95 | 75×10^{-3} | 352.21 | -- | 1 | ≈ 300 |
| MEBT | 3.53 | 3 | 352.21 | -- | -- | ≈ 300 |
| DTL | 32.58 | 3 | 352.21 | -- | 4 | ≈ 300 |
| Spoke | 58.46 | 79 | 352.21 | 0.50 | 14 (2C) | ≈ 2 |
| Medium Beta | 113.84 | 201 | 704.42 | 0.67 | 15 (4C) | ≈ 2 |
| High Beta | 227.86 | 623 | 704.42 | 0.92 | 15 \times 2 (4C) | ≈ 2 |
| HEBT (Projection) | 158.66 | 2500 | -- | -- | -- | -- |



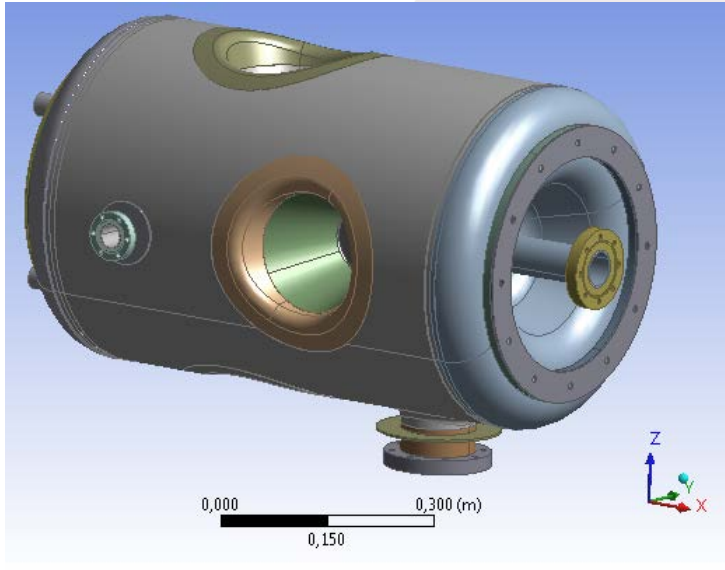

Spoke cavity & cryomodule (IPNO)

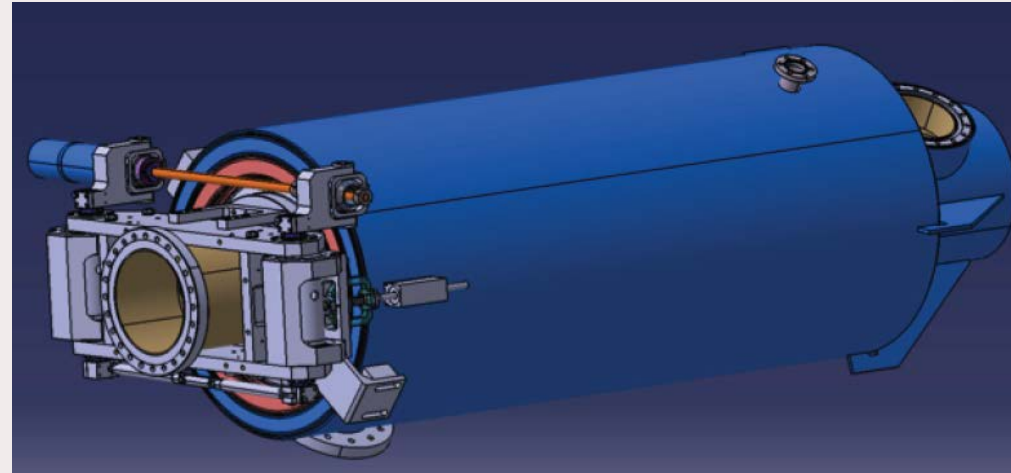

**Elliptical cavity & cryomodule
(IRFU + IPNO)**

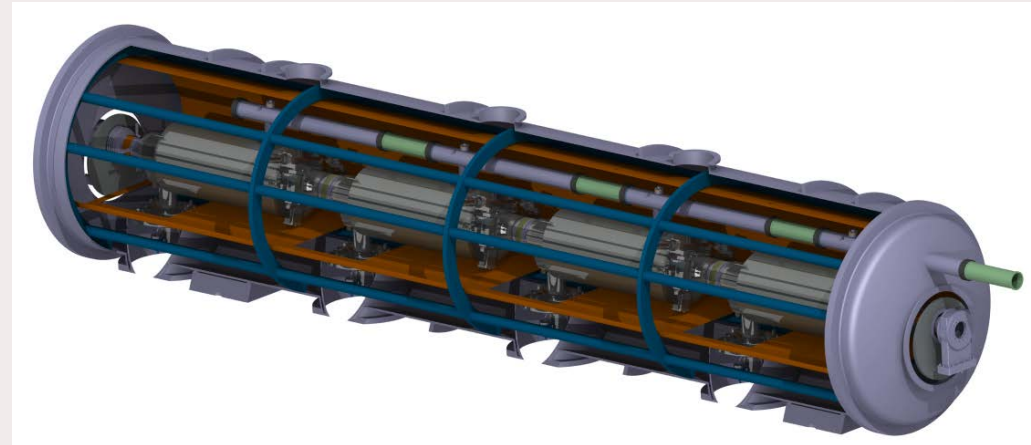
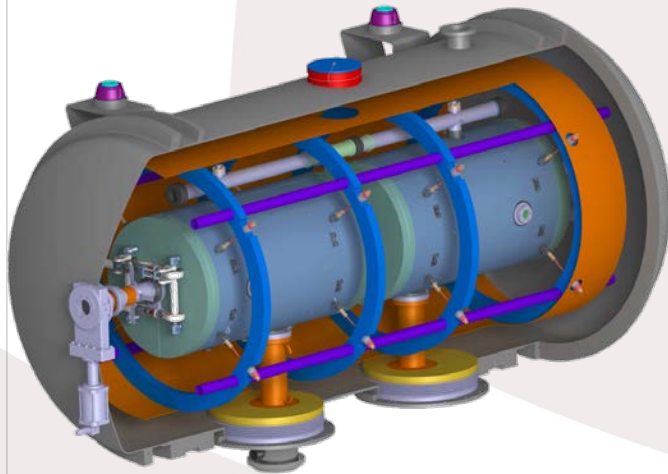

The RF Design of the spoke cavity is performed using CST Microwave Studio code.

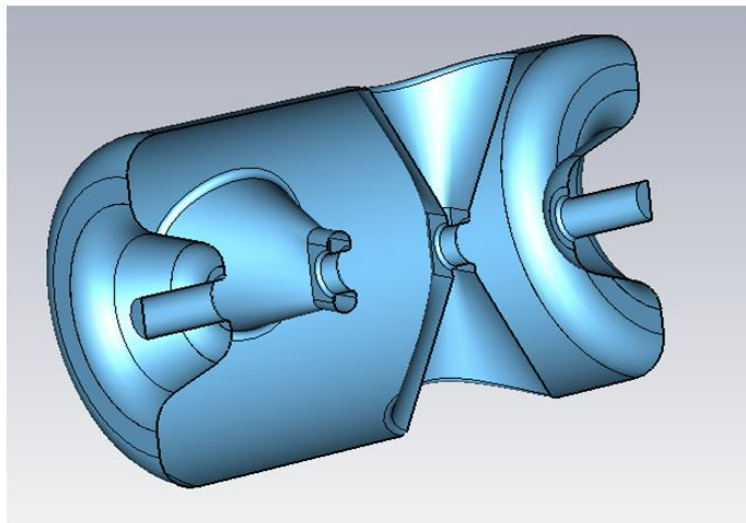

Cavity RF parameters

| | |
|--|----------------------------|
| R/Q | 426 Ω |
| G | 130 Ω |
| Q_0 at 4K (with $R_{res} = 10$ n Ω) | $2.6 \cdot 10^9$ |
| Q_0 at 2K (with $R_{res} = 10$ n Ω) | $1.2 \cdot 10^{10}$ |
| E_{pk} / E_{acc} | 4.43 \rightarrow 35 MV/m |
| B_{pk} / E_{acc} | 7.08 \rightarrow 56 mT |

Peak fields @ 8 MV/m

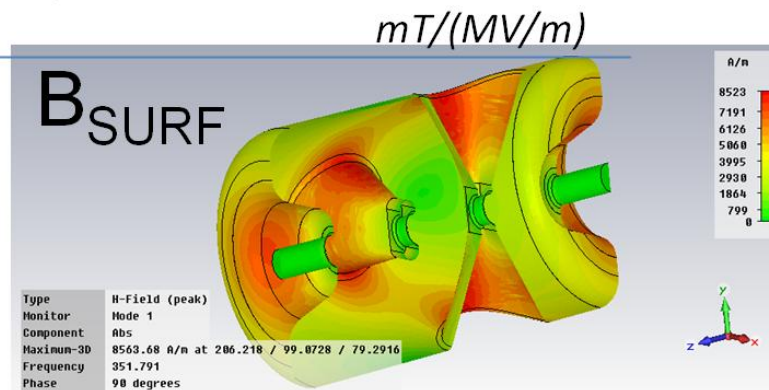
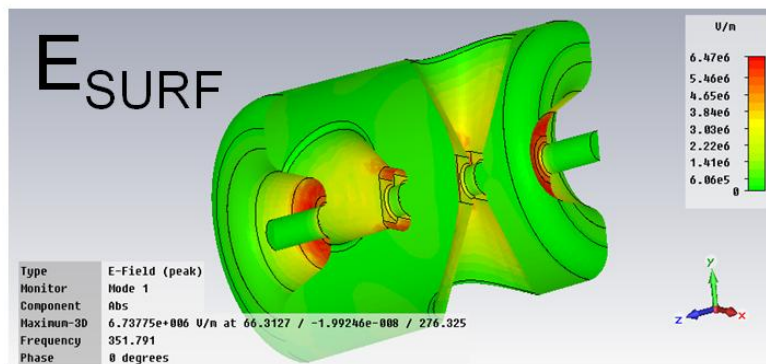

Design of the cavity

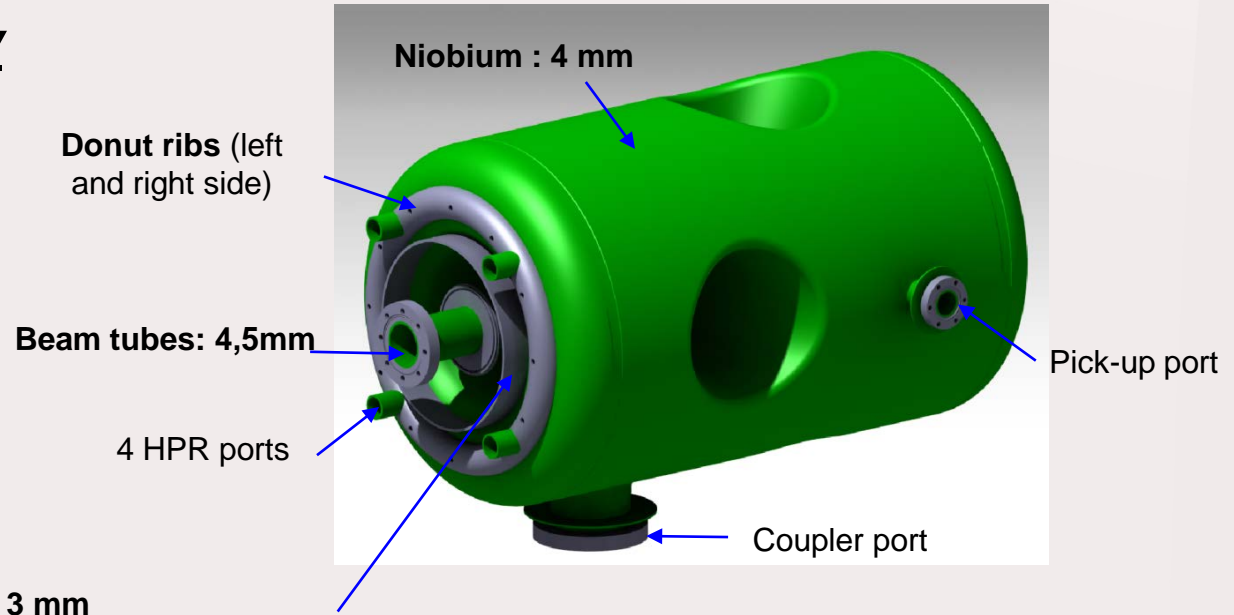

Helium vessel

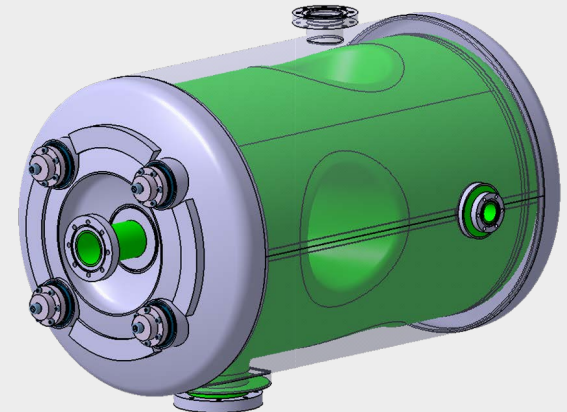
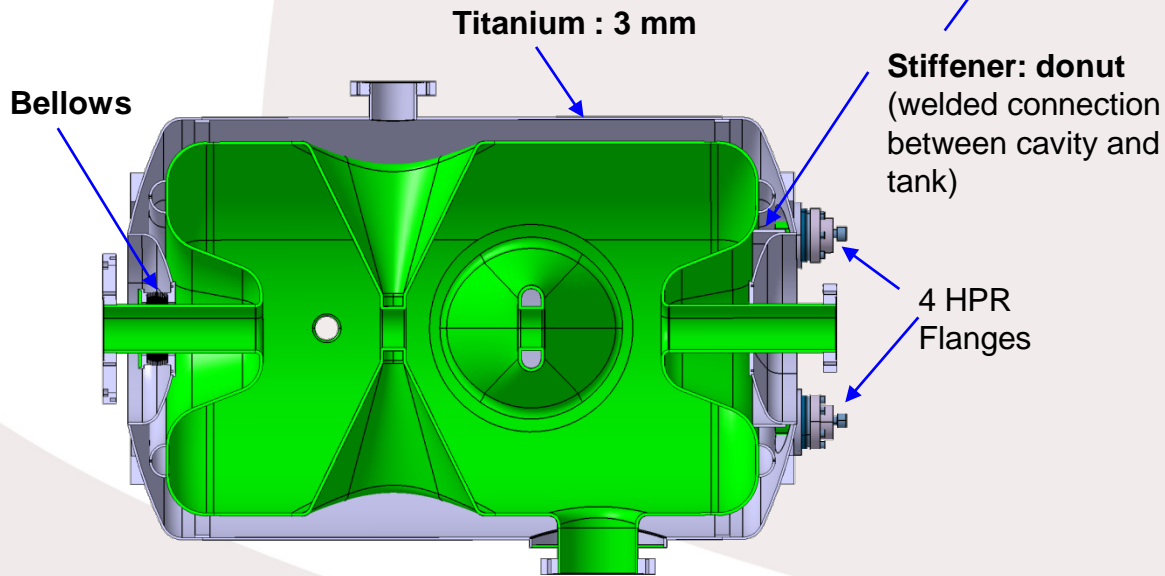

Config. 1 : Cavity without helium vessel (leak test)

Hypothesis :

- **Loads:**
Cavity walls : $P_{ext} = 1 \text{ bar}$
- **Boundary conditions:**
Only **one end beam tube fixed**

Niobium:

$E = 107 \text{ GPa}$
 $\nu = 0,38$
 $Re (20^\circ\text{C}) = 50 \text{ MPa}$

Titanium grade 2:

$E = 105 \text{ GPa}$
 $\nu = 0,3$
 $Re (20^\circ\text{C}) = 350 \text{ MPa}$

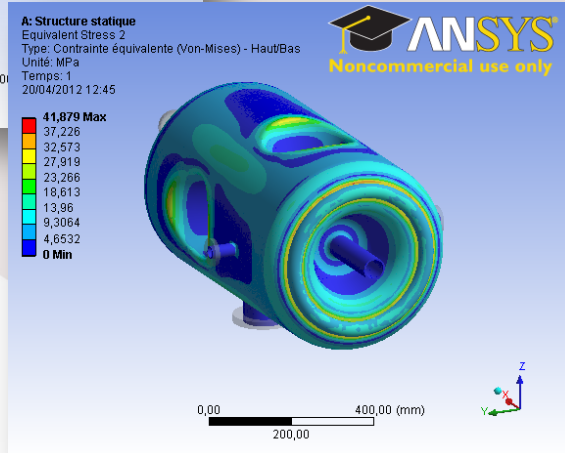
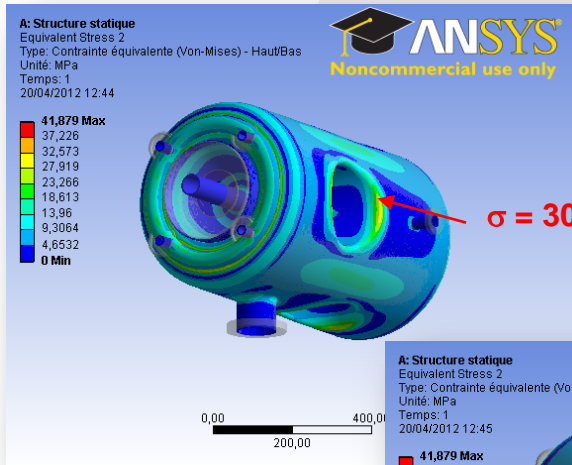

Config. 2 : Cavity with helium vessel (Cool down)

Hypothesis :

- **Loads:**
Cavity walls : $P_{ext} = 1 \text{ bar}$
Vessel walls : $P_{int} = 1 \text{ bar}$
- **Boundary conditions:**
Only **one end beam tube fixed**

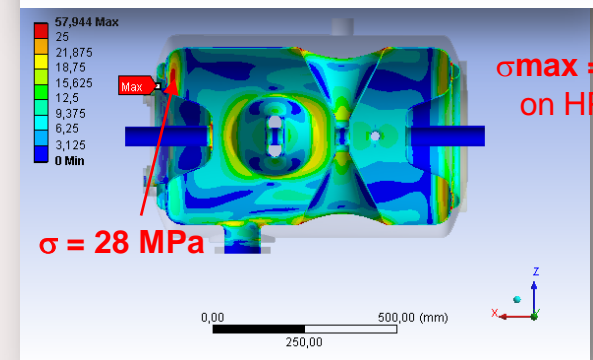
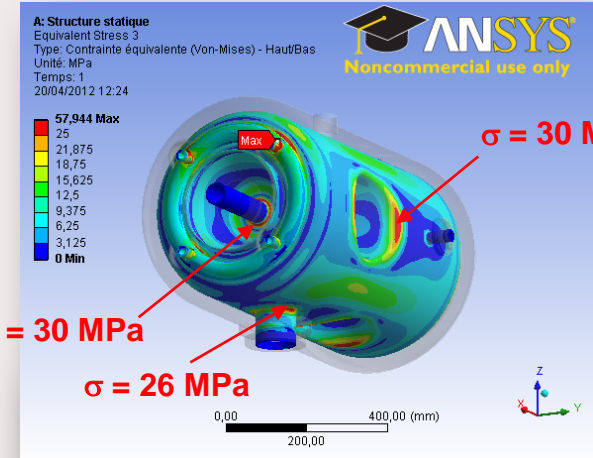

Elliptical cavities design (beta 0.9): RF Design

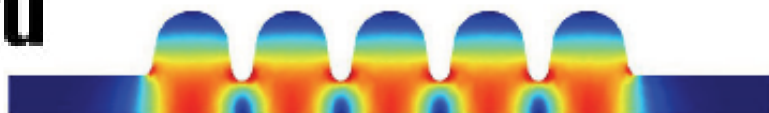

Mode fondamental @704,42 MHz

Advantages of high cell to cell coupling for TM_{01} :

- easier to obtain field flatness, control over peak fields distribution among cells
- more consistent Q_{ext} across cavities
- enhanced mode separation between π and $4\pi/5$ modes
- HOM also better coupled to the outer cells (needed for damping)

Courtesy J.Plouin

| DESIGN PARAMETERS | RF frequency | 704.42 MHz |
|-------------------|-------------------------|------------------|
| | Cavity geometrical beta | 0.86 |
| | Accelerating gradient | 18 MV/m |
| | Q_0 at nominal field | $> 6 \cdot 10^9$ |
| | Maximum surface E field | 40 MV/m |
| | Average pulse current | 50 mA |
| | Peak RF power | 900 kW |
| | Repetition frequency | 14 Hz |
| | Beam pulse length | 2.86 ms |
| | Operating Temperature | 2 K |

| RF PARAMETERS | Bpk/Eacc [mT/(MV/m)] | 4.3 |
|---------------|---|-------------|
| | Epk/Eacc | 2.2 |
| | G [Ohm] | 241 |
| | Cell to cell coupling | 1.8 % |
| | r/Q [Ohms] | 477 |
| | $L_{acc} = N_{gap} \cdot \beta \cdot \lambda / 2$ [m] | 0.915 |
| | Cell wall angle | $> 8^\circ$ |

Elliptical cavities design (beta 0.9)

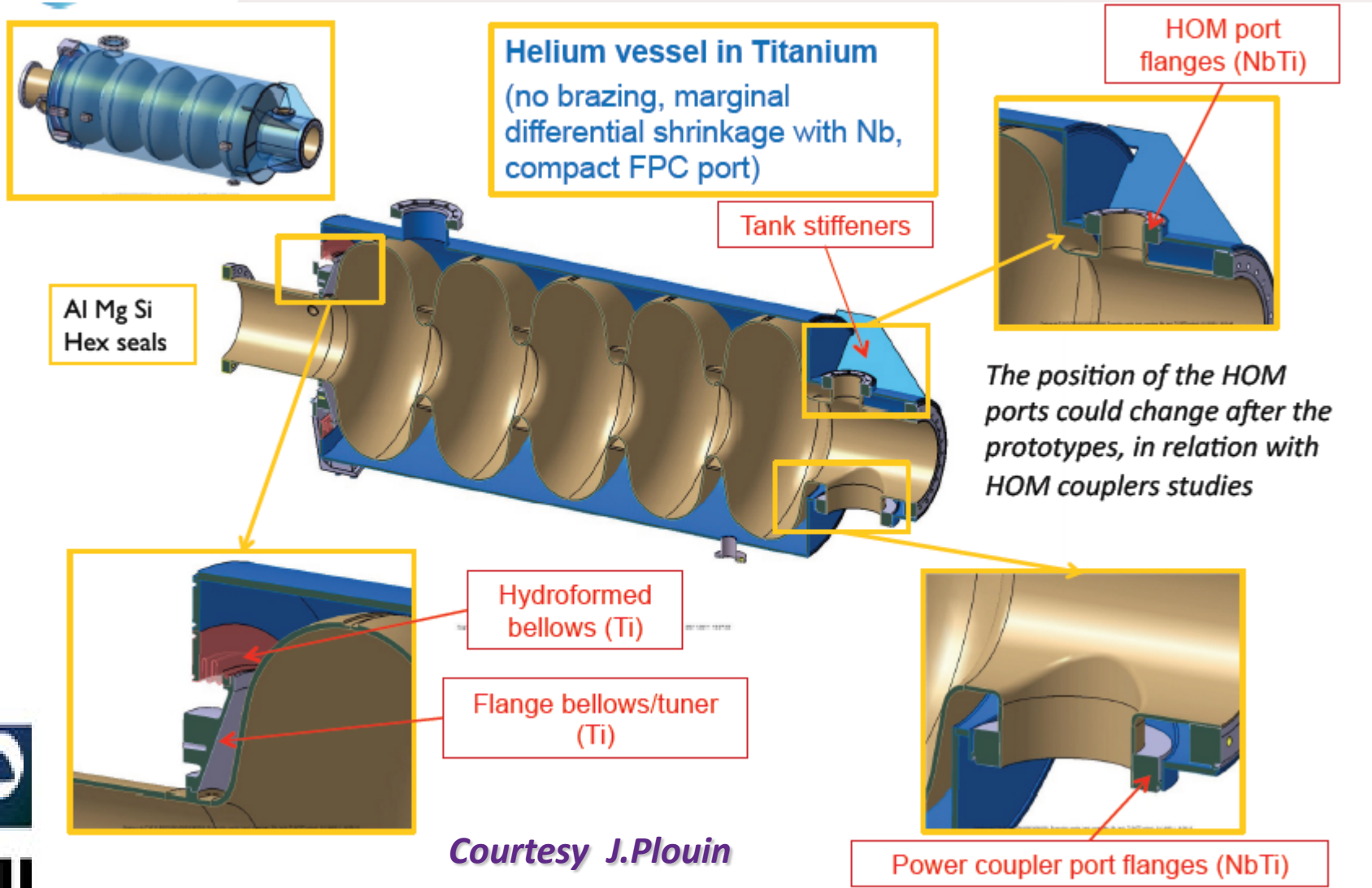

Elliptical cavities design (beta 0.9): HOM Study

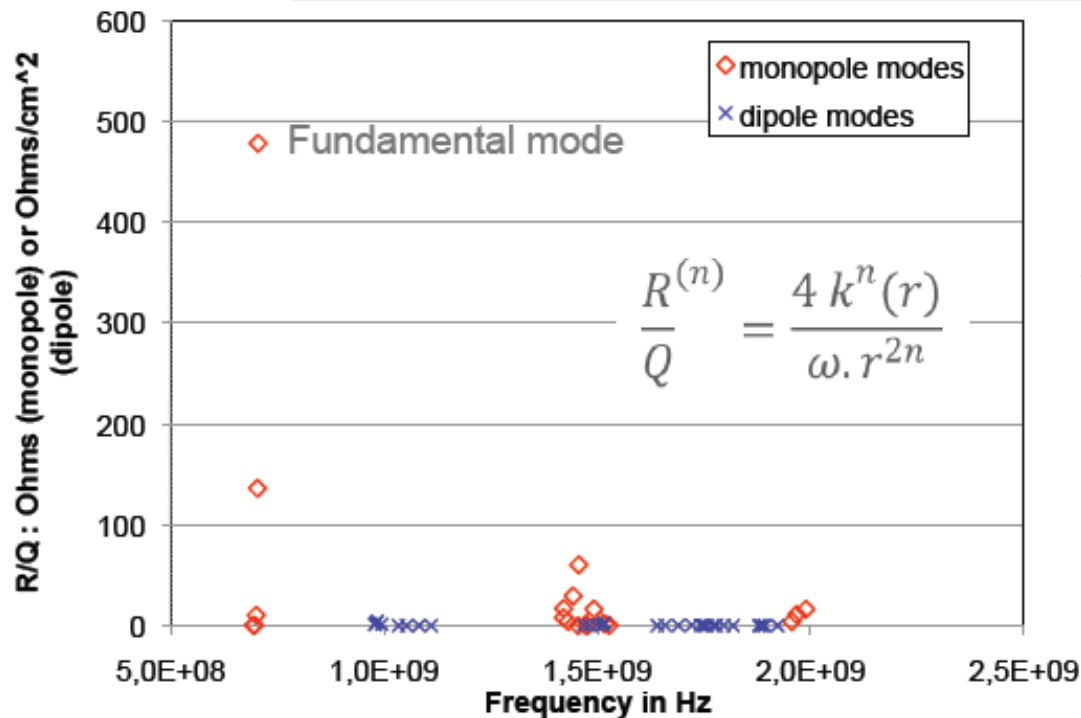

All HOM have been identified up to 2 GHz, with r/Q calculated



2 monopolar modes identified around 1420 MHz.
 Closest machine line at 1408,8MHz= 2x704.4 MHz, i.e. 11.2 MHz apart. Matching the mode and the machine line would require a cavity elongation of 28 mm

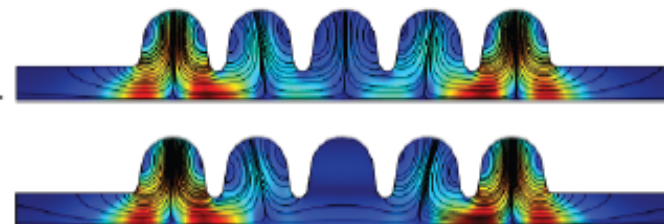

Courtesy J.Plouin

HIE ISOLDE (Cern)



Project objectives: post-accelerate the RIB beam coming from REX-ISOLDE up to 10 MeV/u (intermediate phase at 5.5 MeV/u).

Cavity type: Quarter-wave resonators, Nb/Cu, $f=101.28$ MHz

- SC-linac between 1.2 and 10 MeV/u
- 32 SC QWR (20 cavities @ $\beta=0.1$ and 12 cavities @ $\beta=0.06$)

Performances goal: $E_{acc} = 6$ MV/m and 7 W max of dissipated power

Objectives based on past experience at INFN-Legnaro on sputtered cavities developed for ALPI

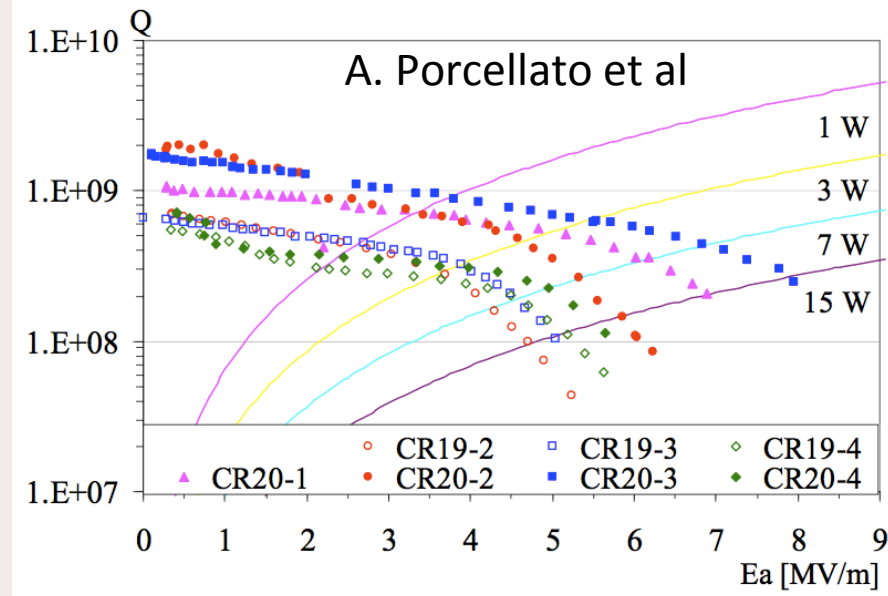

Cavity features:

- Cavity substrate: OFE copper, 10 mm thick, cold worked; deep drawing and EB welding at CERN. A new design and fabrication process is ongoing.
- Specially studied beam aperture shapes (racetrack) to minimize the beam steering effect of QWR.
- Op. T° 4.2 K, LHe only on the cavity top and in the stem.

Low β

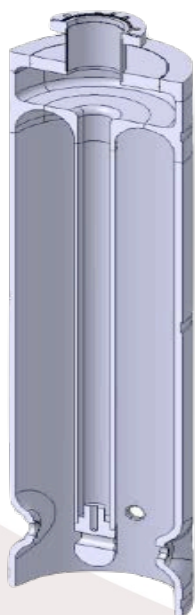

High β



Courtesy M. Pasini

Table 1: Cavity design parameters

| Cavity | Low β | high β |
|---|------------------|----------------|
| No. of Cells | 2 | 2 |
| f (MHz) | 101.28 | 101.28 |
| β_0 (%) | 6.3 | 10.3 |
| Design gradient E_{acc} (MV/m) | 6 | 6 |
| Active length (mm) | 195 | 300 |
| Inner conductor diameter (mm) | 50 | 90 |
| Mechanical length (mm) | 215 | 320 |
| Gap length (mm) | 50 | 85 |
| Beam aperture diameter (mm) | 20 | 20 |
| U/E_{acc}^2 (mJ/(MV/m) ²) | 73 | 207 |
| E_{pk}/E_{acc} | 5.4 | 5.6 |
| H_{pk}/E_{acc} (Oe/MV/m) | 80 | 100.7 |
| R_{sh}/Q (Ω) | 564 | 548 |
| $\Gamma = R_s \cdot Q_0$ (Ω) | 23 | 30.6 |
| Q_0 for 6MV/m at 7W | $3.2 \cdot 10^8$ | $5 \cdot 10^8$ |
| TTF max | 0.85 | 0.9 |
| No. of cavities | 12 | 20 |

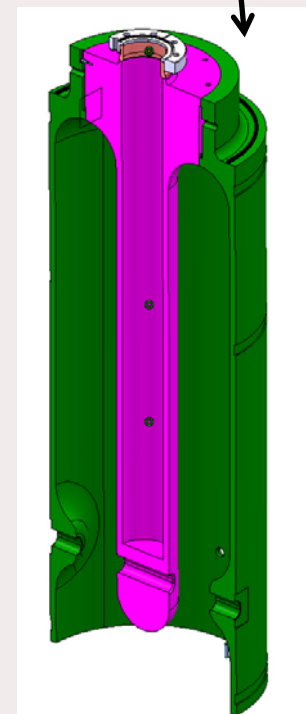

New mechanical design, for a 3D fabrication from a billet

Sputtering: 2 techniques are studied: bias diode and magnetron sputtering



Bias Diode Sputtering

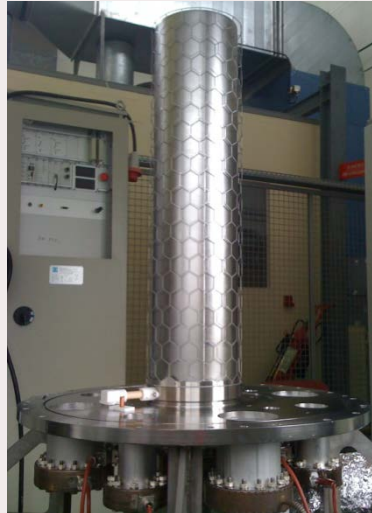

Magnetron Sputtering



First prototype

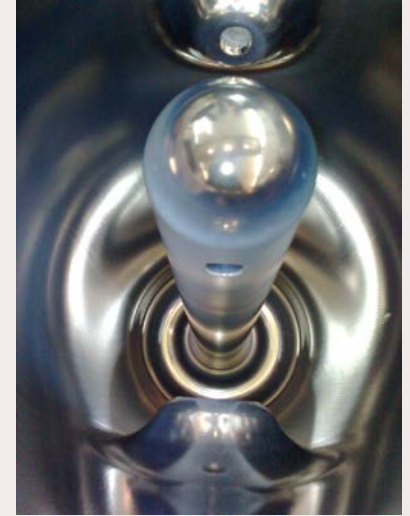

Courtesy M. Pasini



Latest RF tests on prototypes: accelerating field close to nominal achieved, and Q_0 issues almost solved.

Optimization of deposition parameters are still ongoing (main goal: increase the RRR of the Nb film)

EUCARD – SPL activities (CERN, CEA, IPNO)

Framework: Design, fabricate and test one prototype of a 700 MHz beta 0.65 elliptical (5-cells) superconducting cavity

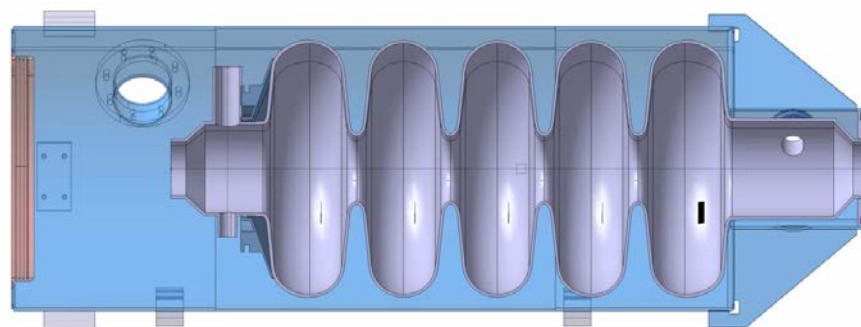
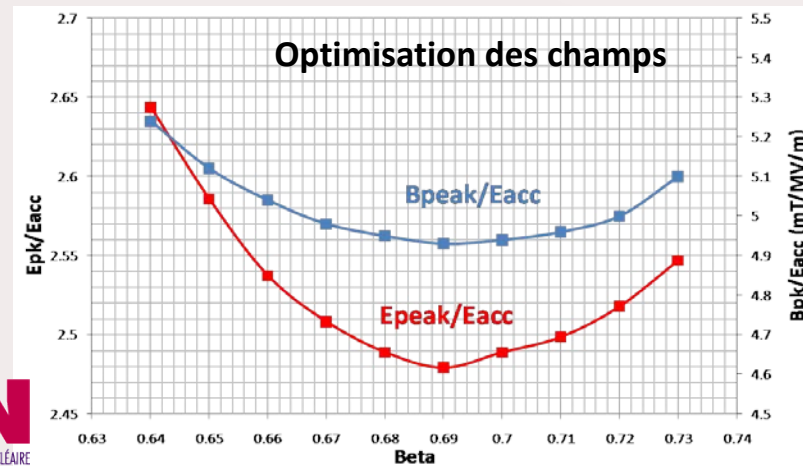
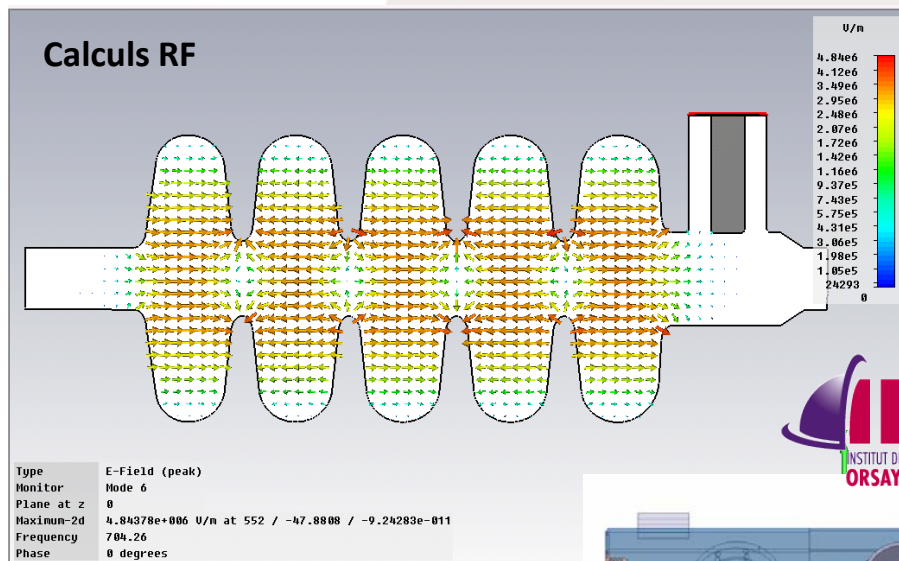

Other design and prototyping activity is ongoing within Eucard:

- 704 MHz elliptical beta = 1 (CEA Irfu)
- power coupler developments (CEA, CERN)

MYRRHA (Mol, Belgium) EU collaboration

Main goal: nuclear waste transmutation with and ADS

- MYRRHA (Multi-Purpose hYbrid Research Reactor for High-tech Applications)
- Project initiated and lead by SCK-CEN (Mol, Belgium)
- Goal: operation ~2023
- ISOL @ MYRRHA possible

Reactor

- subcritical mode (50-100 MWth)
- critical mode (~100 MWth)



Accelerator

(600 MeV – 4 mA proton)

Spallation source



Fast
neutron
source

Multipurpose
flexible
irradiation
facility

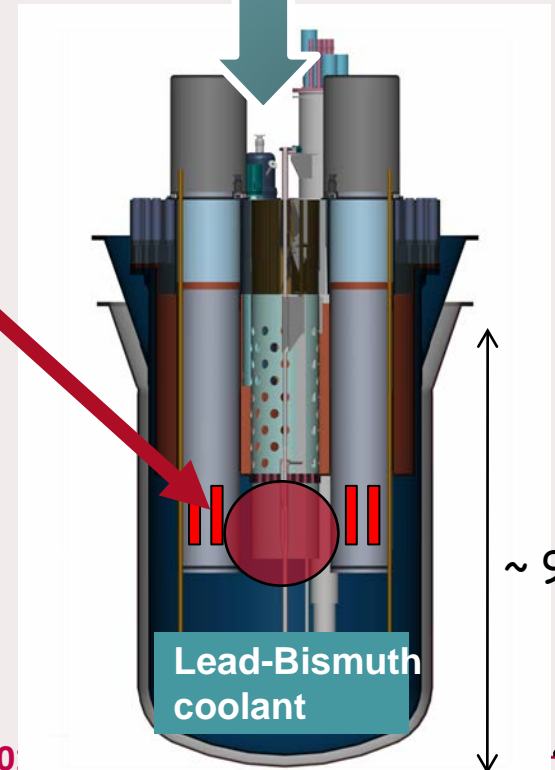

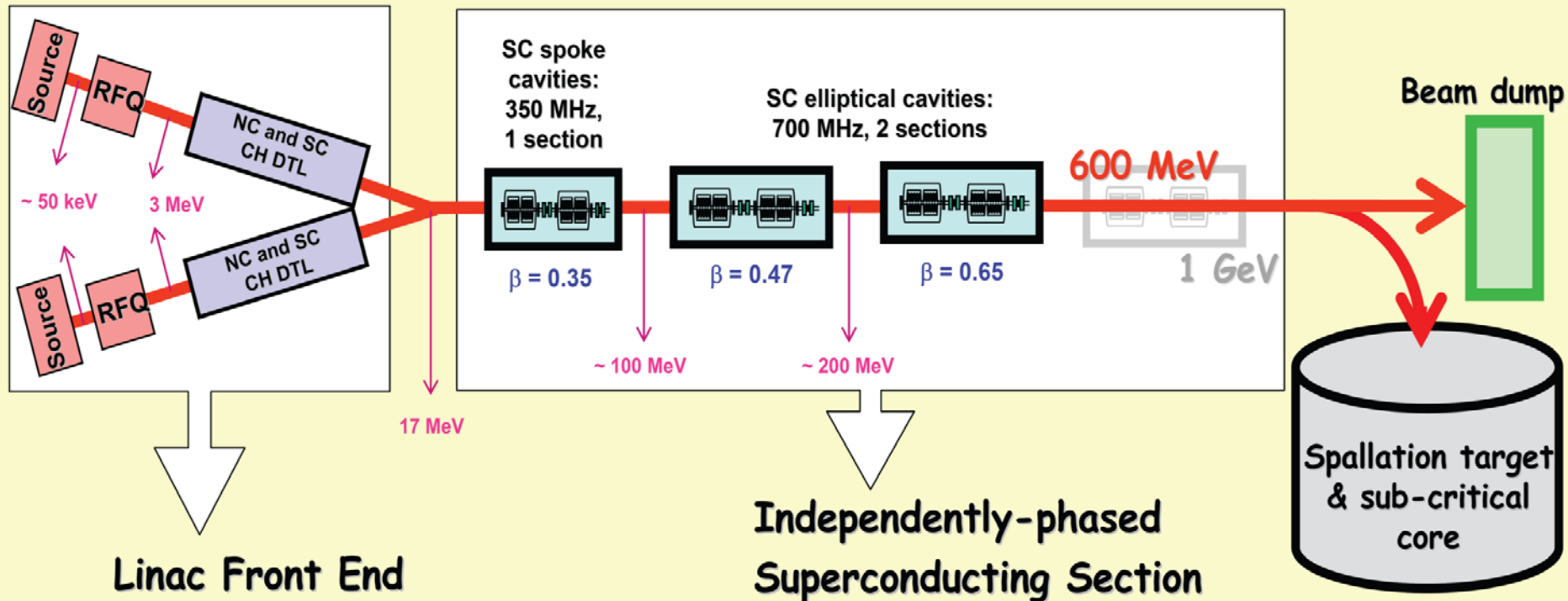

Reliability guidelines have been followed during the ADS accelerator design

- Strong component design & derating: components derated with respect to tech. limitations; prototyping & test on each key components (FP6-7 EU programs)
- Redundancies in critical areas: Front-end duplication, solid-state RF amplifiers
- Capability of fault-tolerant operation : Expected in the highly modular superconducting RF linac (from ~20 MeV) -> Implies reliable and sophisticated digital RF control systems (preset op. set points)

Design, fabrication & test of an elliptical module at nominal power & temperature

- $\beta = 0.47$ prototype constructed and tested
- Vessel & valve box installed and operational
- CW RF power coupler to be conditioned
- 700 MHz RF 80 kW power source received and operational

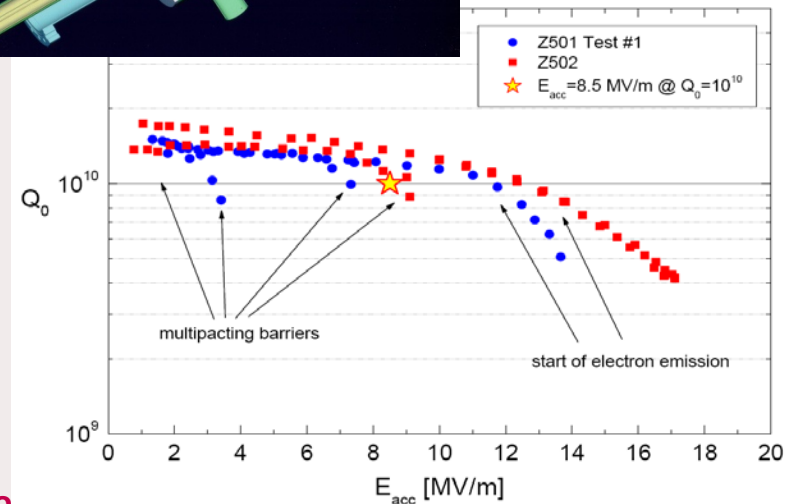
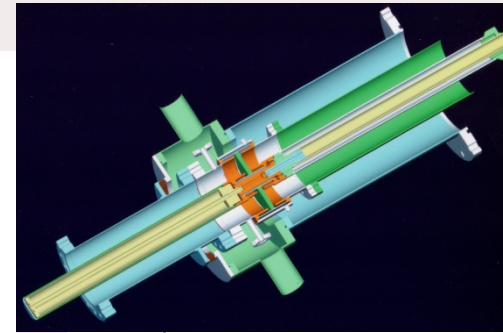
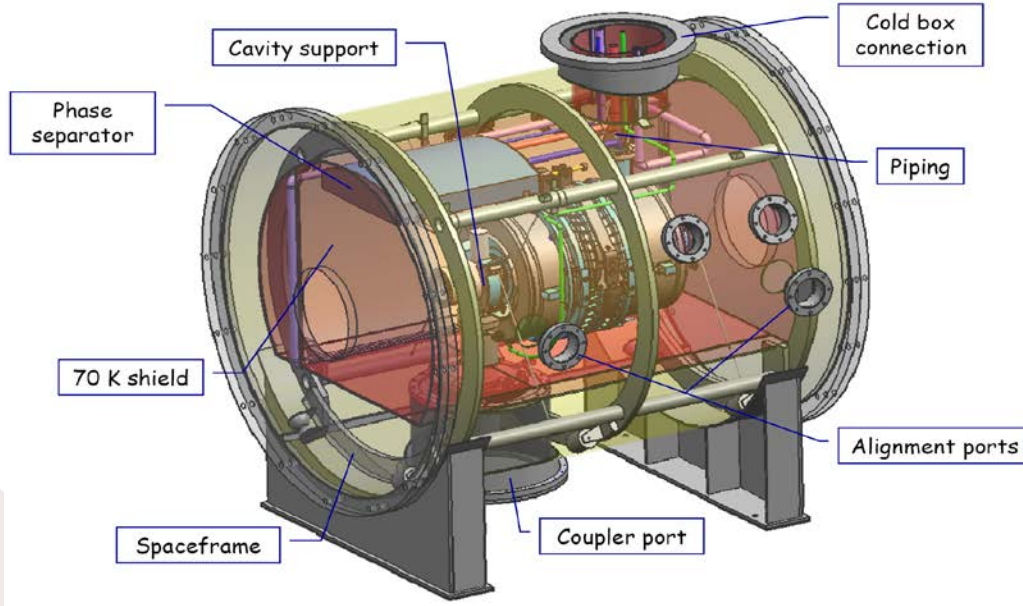
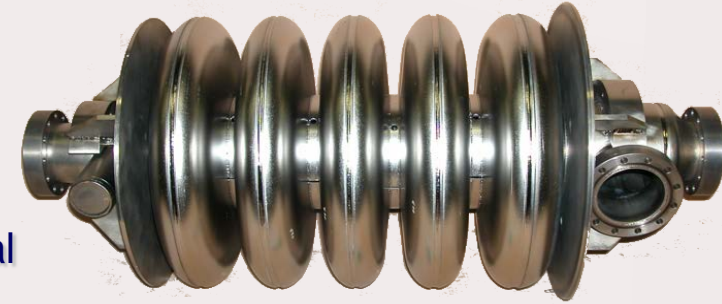
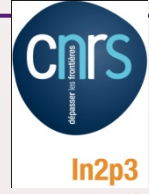

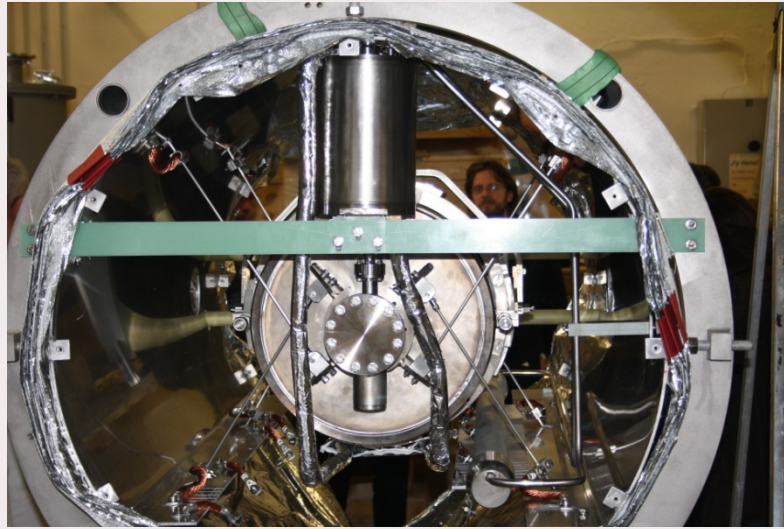
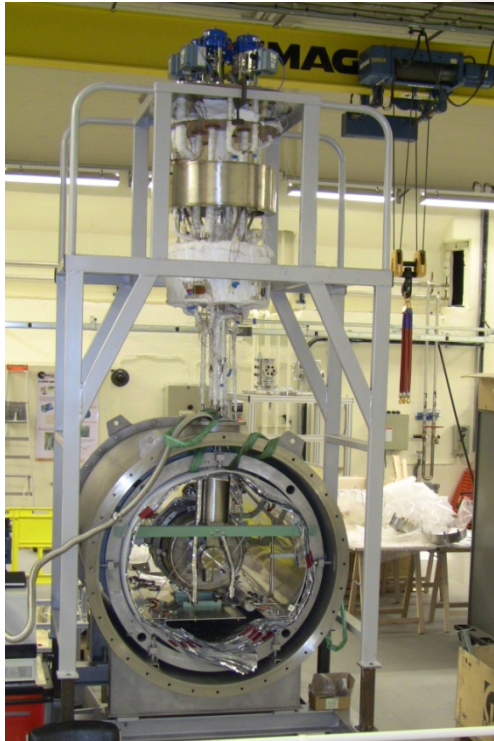

Collaboration with INFN Milano

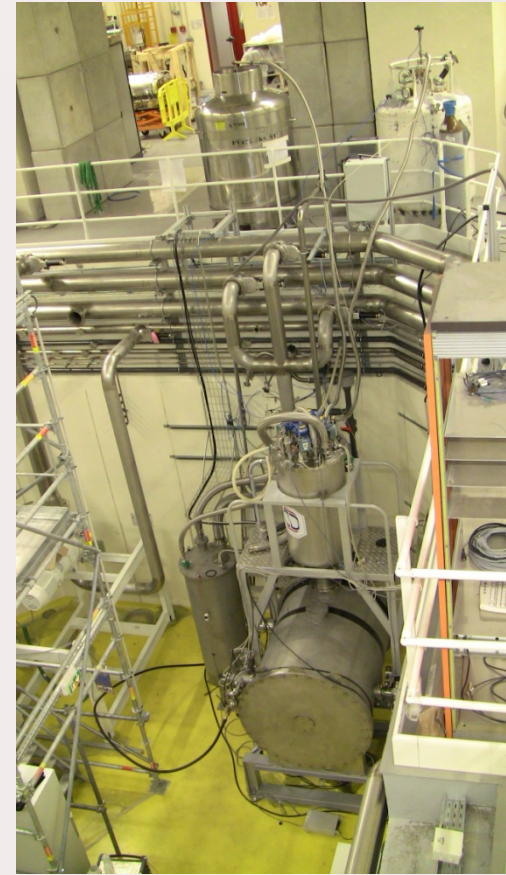

Intense tests (specially long-term) of the one-cavity 704 MHz prototype cryomodule is ongoing (low and then high power).

Conclusions

Superconducting technology:

- Is a **technology of choice** for high power acceleration in general and specially for EURISOL, thanks to intrinsic efficiency and its maturity gained over the past 25 years.
- Can **efficiently accelerate** high (and low...) power ion beam starting from a few MeV/u (starting at $\beta \sim 0.05$)
- The type of cavity and implementation in the accelerator **needs to be carefully chosen** according to beam specifications and requirements: range of β , beam current, variety of beam species to accelerate, final energy, reliability, upgradability, ... and cost !
- The cavity type or design **IS NOT** the whole story: coupling the power to the beam, tuning the cavity, prepare the cavity (dust is a tough and invisible enemy !), integration in a cryomodule are even more potential sources of problems.

$\beta < 1$ superconducting cavities

- SC RF developments is very active in Europe (and worldwide), especially (this is quite recent) for developing low beta cavities ; many projects are under study or construction and drive intense R&D programs on such accelerating structures.

-> Potential for real technological synergies between projects.

- There are many issues faced by all projects for these structures: field emission, multipacting, tuning capabilities, mechanical stiffness, and all required a dedicated study because all cavities are different (cavity type, frequency, β , coupling or tuning solutions)...

- Progress done are tremendous, and in some cases, peak fields achieved start to be comparable with the ones obtained on electron cavities.

THANK YOU !